



**Institut de
Tecnologia de la Construcció
de Catalunya**

Wellington 19
ES08018 Barcelona
T +34 933 09 34 04
qualprod@itec.cat
itec.cat



Member of



www.eota.eu

European Technical Assessment

ETA 09/0115
of 04.09.2019



General part

Technical Assessment Body issuing the ETA: ITeC	
ITeC has been designated according to Article 29 of Regulation (EU) No 305/2011 and is member of EOTA (European Organisation for Technical Assessment)	
Trade name of the construction product	PF-ALU-PL kit
Product family to which the construction product belongs	Subframe and fixing kit for fastening cladding elements and also external wall elements in ventilated or non-ventilated façades
Manufacturer	MECANISMOS, ANCLAJES Y SISTEMAS AUTOPORTANTES SL - MASA C/ Compositor Bach, 14-16 Pol. Ind. Can Jardí ES-08191 RUBÍ Barcelona, Spain
Manufacturing plant(s)	C/ Compositor Bach, 14-16 Pol. Ind. Can Jardí ES-08191 RUBÍ Barcelona, Spain
This European Technical Assessment contains	38 pages including 6 annexes which form an integral part of this assessment.
This European Technical Assessment is issued in accordance with Regulation (EU) 305/2011, on the basis of	European Assessment Document, EAD 090034-00-0404 <i>Kit composed by subframe and fixings for fastening cladding and external wall elements.</i>
This version replaces	ETA 09/0115 issued on 07.06.2013.

General comments

Translations of this European Technical Assessment in other languages shall fully correspond to the original issued document and should be identified as such.

Communication of this European Technical Assessment, including transmission by electronic means, shall be in full. However, partial reproduction may be made, with the written consent of issuing Technical Assessment Body. Any partial reproduction has to be identified as such.

Specific parts of the European Technical Assessment

1 Technical description of the product

PF-ALU-PL kit for fastening skin elements¹ (cladding elements and external wall elements) consists of:

- Skin element fixing device according to Type 3 given in EAD 090034-00-0404:
 1. Stainless steel fixing devices GR-PL for fastening skin elements.
 2. Stainless steel drilling screws between the fixing devices and the subframe profile.
 3. Ancillary component: plastic rail protector.
- Subframe:
 4. Aluminium alloy vertical profiles PF-AL-U.
 5. Brackets:
 - Aluminium alloy brackets ES-ALU-A, ES-ALU-V and ES-ALU-E.
 - Stainless steel brackets ES-INOX-E and ES-INOX-A.
 6. Stainless steel drilling screws between the subframe profiles and brackets.

The GR-PL fixing devices are stainless steel rail anchors for skin elements with groove.

One fixing bears two or four skin elements. And four fixings are needed to support one skin element.

The PF-ALU-PL kit is made of mechanical components. Adhesives are not needed for assembly.

The PF-ALU-PL kit is a non-load bearing construction element. It does not contribute to the stability of the structure on which it is installed.

The following ventilated façade elements or components are not considered in this ETA:

- The skin elements².
- The fixings between the subframe and the supporting structure³.
- The other layers of the façade, like insulation and internal layers.

The geometry characteristics and the material properties of each component are given in annexes indicated in the following table:

Table 1.1: Annexes of geometry characteristics and material properties of the kit components.

Component	Geometry characteristics and material annexes
Skin fixing devices GR-PL	Annex 2
Vertical Profiles	Annex 3
Brackets	Annex 4
Drilling screws	Annex 5

¹ From now on this term refers to both cladding elements and external wall elements.

² If the skin elements are cladding elements, other EADs may apply (e.g. EAD 090062, EAD 090020, etc.).

³ The term "supporting structure" refers to both of followings descriptions:

- The wall, which in itself already meets the airtightness and mechanical strength requirements (resistance to static and dynamic loads). The substrate walls are made of masonry (clay, concrete or stone), concrete (cast on site or as prefabricated panels), timber or metal frame.
- The supporting structure of the building, which in itself does not meet the airtightness requirement but meets the mechanical strength requirements (resistance to static and dynamic loads). Usually, the supporting structures of the building are made of concrete (cast on site or prefabricated), timber or metal frame.
In this case, the airtightness requirements are met by the internal leaves of the façade.

2 Specification of the intended use(s) in accordance with the applicable European Assessment Document (hereinafter EAD)

PF-ALU-PL kit is intended to be used as mechanical fastening of skin elements (claddings or external wall elements) in façades with air space, ventilated or not, and intended to be used on supporting structures³ which meet the mechanical strength requirements.

The PF-ALU-PL kit is intended to be used for the fixing of skin elements (e.g. natural stone according to EN 1469) with groove (see section A6.1 of Annex 6 for more information on the skin element specifications).

The skin elements are not part of the kit object of this ETA. The safety in use of the skin elements has to be assessed separately.

The provisions made in this European Technical Assessment are based on an assumed working life of at least 25 years for PF-ALU-PL kit. The indications given on the working life cannot be interpreted as a guarantee given by the producer, but are to be regarded only as a means for choosing the right products in relation to the expected economically reasonable working life of the works.

PF-ALU-PL kit is made of non-load bearing construction components. They do not contribute directly to the stability of the wall on which they are installed.

PF-ALU-PL kit is not intended to ensure the airtightness of the building envelope.

Detailed information and data regarding design, installation, maintenance and repair criteria are given in Annex 6.

3 Performance of the product and reference to the methods used for its assessment

The assessment of PF-ALU-PL kit for the intended use was performed following the EAD 090034-00-0404 *Kit composed by subframe and fixings for fastening cladding and external wall elements*.

Table 3.1: Summary of the PF-ALU-PL kit performances (see also detailed performances in relevant sections).

Product:	PF-ALU-PL kit	Intended use:	Mechanical fastening of skin elements (claddings or external wall elements) in façades with air space, ventilated or not.
Basic Works Requirement	ETA section	Essential characteristic	Performance
BWR 2 Safety in case of fire	3.1	Reaction to fire	A1
	3.2	Wind load resistance	3000 Pa (suction) 4000 Pa (pressure)
BWR 4 Safety and accessibility in use	3.3	Resistance to vertical load of the kit	≤ 0,02 mm after 1 hour
	3.4	Resistance to vertical load of skin element fixing	See table 3.3
	3.5	Resistance to horizontal load of skin element fixing	See table 3.4
	---	Resistance to pulsating load of skin element fixings	Not assessed
	---	Resistance of skin element fixings in case of inaccuracies of installation	Not relevant
	3.6	Pull-through resistance of fixings from profile	10,0 kN
	3.7	Pull-out resistance of subframe fixings from profile	3,47 kN
	3.8	Inertia and resistance of profiles	See Annex 3
	3.9	Resistance of vertical load of brackets	See table 3.7
	3.10	Resistance of horizontal load of brackets	See table 3.8
3.11	Mechanical characteristics of subframe fixings	See table 3.6	
3.12	Corrosion	See section 3.12	

Complementary information:

Requirements with respect to the mechanical resistance and stability of non-load bearing parts of the works are not included in the Basic Works Requirement *Mechanical resistance and stability* (BWR 1) but are treated under the Basic Works Requirement *Safety and accessibility in use* (BWR 4).

The fire resistance requirement is applicable to the wall (made of masonry, concrete, timber or metal frame) and not to the PF-ALU-PL kit itself.

3.1 Reaction to fire

Reaction to fire of PF-ALU-PL kit according to Commission Delegated Regulation (EU) 2016/364 and EN 13501-1 is Class A1 without need of testing according to Decision 96/603/EC as amended.

The rail protectors can be considered small components, so they can be ignored and do not need to be tested for their reaction to fire performance.

Note: A European reference fire scenario has not been laid down for façades. In some Member States, the classification of external wall claddings according to EN 13501-1 might not be sufficient for the use in façades. An additional assessment of external wall claddings according to national provisions (e.g. on the basis of a large-scale test) might be necessary to comply with Member State regulations, until the existing European classification system has been completed.

3.2 Wind load resistance

PF-ALU-PL kit wind load resistance has been determined according to section 2.2.2 of EAD 090034-00-0404 considering the wind suction and pressure resistance tests and the mechanical resistance of the components (see sections 3.4 to 3.11). Test results and calculated values for the tested are given in table 3.2.

For other assembled systems, wind load resistance obtained by calculation on the basis of the mechanical resistance of the kit components should not be higher than the maximum load obtained in the tests.

Table 3.2: Test results and calculated values for tested specimen.

Test results (1)				Calculated values
Test	Maximum load Q (Pa)	Deflection under maximum load (mm)	Deflection after 1 min recovery (mm)	Load (Pa) (4)
Suction	3000 (2)	21,6 (3)	3,28	3460
Pressure	4000 (2)	9,65 (3)	3,03	

(1) Tested specimen: skin element 681x789x30 mm; fixing device GR-PL-100 and GR-PL-46 for the borders; three PF-ALU-80 vertical profiles (minimum vertical profile dimension for the span 2700 mm), span 681 mm; brackets ES-ALU-A/V 87/200, span 2700 mm. Characteristics of components are indicated in Annexes 2 and 3.
(2) This load has been obtained at the test equipment limit without PF-ALU-PL kit failure.
(3) Deflection measured at the central vertical profile.
(4) Calculated load for tested specimen configuration considering 1 mm of irreversible deformation (F_c) of the fixing device. Calculated values for tested specimen composition using simple beam formulas.

3.3 Resistance to vertical load of the kit

Resistance to vertical load of PF-ALU-PL kit has been assessed according to section 2.2.3 of EAD 090034-00-0404.

The maximum vertical dead load considered in the test is 2,59 kN for the PF-ALU-PL kit (each fixing device supports 1,29 kN). This value is higher than those indicated in table 3.3 as the characteristic values F_c at 1 mm irreversible deformation.

The maximum deflection obtained has been 0,02 mm after 1 hour.

3.4 Resistance to vertical load of skin element fixing

Resistance to vertical load of GR-PL fixing devices has been assessed according to section 2.2.4 of EAD 090034-00-0404. Mean and characteristic values are given in table 3.3.

Table 3.3: Resistance to vertical load of skin element fixing GR-PL.

Fixing device type ⁴	Load at 1 mm irreversible deformation			Failure load	
	F _m (kN)	F _c (kN)	F _{u,m} (kN)	F _{u,c} (kN)	Maximum deformation (mm)
GR-PL-46	1,29	0,66	4,50	3,87	24,7
GR-PL-100	1,23	0,98	6,99	6,34	27,5
GR-PL-100/2	1,85	0,50	2,30	1,91	2,9

Where: F_m is the mean value.
F_c is the characteristic value given at 75% confidence that 95% of test results will be higher than this value.

3.5 Resistance to horizontal load of skin element fixing

Resistance to horizontal load of GR-PL fixing devices has been assessed according to section 2.2.5 of EAD 090034-00-0404. Mean and characteristic values are given in table 3.4.

Table 3.4: Resistance to horizontal load of skin element fixing GR-PL.

Fixing device type ⁴	Load at 1 mm irreversible deformation			Failure load	
	F _m (kN)	F _c (kN)	F _{u,m} (kN)	F _{u,c} (kN)	Maximum deformation (mm)
GR-PL-46	1,79	0,85	6,96	6,01	10,0
GR-PL-100	2,62	1,85	7,57	6,62	9,2
GR-PL-100/2	1,53	0,95	2,22	1,94	2,9

Where: F_m is the mean value.
F_c is the characteristic value given at 75% confidence that 95% of test results will be higher than this value.

3.6 Pull-through resistance of fixings from profile

Pull-through resistance of fixings from profiles has been assessed according to section 2.2.8 of EAD 090034-00-0404. Mean and characteristic values are given in table 3.5.

Table 3.5: Pull-through resistance failure load value.

Profile type ⁵ (*)	R _s (kN)	R _{sc} (kN)
PF-AL-U-40	10,7	10,0
PF-AL-U-60		
PF-AL-U-80		
PF-AL-U-100		
PF-AL-T-60		
PF-AL-T-80		

Where: R_s is the mean value.

R_{sc} is the characteristic value given at 75% confidence that 95% of test results will be higher than this value.

(*) The drilling screw used in the tests is the stainless steel quality A2-70 indicated in Annex 6.

3.7 Pull-out resistance of fixings from profile

Pull-through resistance of fixings from profiles has been assessed according to section 2.2.9 of EAD 090034-00-0404. Mean and characteristic values are given in table 3.6.

⁴ These components are defined in Annex 2.

⁵ These components are defined in Annex 3.

Table 3.6: Pull-out resistance and shear strength of subframe screws.

Drilling screw type	Pull-out		Shear strength	
	R _m (kN)	R _c (kN)	R _m (kN)	R _c (kN)
M6x25 PB (*)	3,96	3,47	8,96	7,96

Where: R_m is the mean value.
R_c is the characteristic value given at 75% confidence that 95% of test results will be higher than this value.
(*) The drilling screw used in the tests is the stainless steel quality A2-70 indicated in Annex 5.

3.8 Inertia and resistance of profiles

The following characteristics of the profiles are given in Annex 3:

- Form and dimensions of the profiles sections.
- Inertia of the profiles sections.
- Minimum elastic limit of the profiles material.

3.9 Resistance to vertical load of brackets

Resistance to vertical load of brackets has been assessed according to section 2.2.11 of EAD 090034-00-0404. Mean and characteristic values are given in table 3.7.

Table 3.7: Bracket resistance to vertical load.

Bracket type ⁶ (mm)	Resistance (kN) at 1 mm of displacement (**)		Resistance (kN) at 3 mm of displacement (**)		Resistance (kN) at $\Delta L = 0,2\% \cdot L$ mm of permanent deflection (**)		Ultimate resistance (kN) (**)	
	F _m	F _c	F _m	F _c	F _m	F _c	F _m	F _c
	ES-ALU-A ES-ALU-V							
45/100	3,9	2,7	13,3	10,3	1,8	0,5	25,0	25,0
67/100 (*)	2,6	2,2	5,2	4,1	1,8	1,4	13,0	11,2
87/100								
117/100	2,6	1,4	5,7	4,8	2,8	0,3	15,0	15,0
148/100	1,2	0,7	3,1	2,3	1,2	0,1	12,5	12,5
177/100	1,3	1,1	2,9	2,5	2,4	1,7	10,0	10,0
208/100	1,0	0,5	2,1	1,5	2,1	0,6	7,5	7,5
238/100 (*)	0,7	0,4	1,7	1,5	2,7	1,6	6,5	5,6
267/100								
ES-INOX-A								
238/100 (*)	0,8	0,6	1,5	1,3	1,5	1,2	2,9	2,8
267/100								
296/100 (*)	0,7	0,4	1,2	1,0	1,7	1,4	2,4	2,2
325/100								
ES-ALU-E								
67/200 (*)	6,8	5,5	17,4	13,6	4,1	2,8	30,9	28,7
87/200								
117/200	4,8	2,7	12,3	8,2	2,4	2,0	25,0	25,0
148/200	3,2	2,7	8,3	6,3	3,3	3,0	17,5	17,5
177/200	2,0	1,2	5,5	4,5	1,9	1,2	12,5	12,5
208/200	2,4	1,7	5,5	3,6	3,1	0,8	13,3	8,5
238/200 (*)	2,9	1,6	5,8	3,1	7,5	7,1	20,0	19,4
267/200								

⁶ These components are defined in Annex 4.

Table 3.7: Bracket resistance to vertical load.

Bracket type ⁶ (mm)	Resistance (kN) at 1 mm of displacement (**)		Resistance (kN) at 3 mm of displacement (**)		Resistance (kN) at $\Delta L = 0,2\% \cdot L$ mm of permanent deflection (**)		Ultimate resistance (kN) (**)	
	F _m	F _c	F _m	F _c	F _m	F _c	F _m	F _c
	ES-INOX-E	2,9	2,0	5,8	4,5	6,2	3,4	10,0
238/200 (*)								
267/200								
296/200 (*)								
325/200	2,2	2,0	4,5	3,8	5,6	3,9	11,2	8,3

Where:

F_m = mean values; F_c = characteristic values giving 75% confidence that 95% of results will be higher than this value.

(*) Bracket not tested. Values from another representative bracket.

(**) When the bracket includes the thermal bridge break piece (see Annex 4), these resistance values shall be reduced applying a reduction factor = 0,80.

3.10 Resistance to horizontal load of brackets

Resistance to horizontal load of brackets has been assessed according to section 2.2.12 of EAD 090034-00-0404. Mean and characteristic values are given in table 3.8.

Table 3.8: Bracket resistance to horizontal load.

Bracket type ⁶ (mm)	Resistance (kN) at 1 mm of permanent deflection		Ultimate resistance (kN)	
	F _m	F _c	F _m	F _c
ES-ALU-A	5,8	5,1	11,6	9,9
ES-ALU-V	8,3	7,0	15,4	14,7
ES-INOX-E	10,4	8,4	18,7	15,4
ES-ALU-E	10,6	10,3	20,0	17,4
ES-INOX-E	10,5	8,2	20,3	18,6
ES-ALU-A	10,5	8,7	20,1	18,6
ES-ALU-V	18,2	15,6	18,8	17,0
ES-INOX-E	11,4	7,5	18,1	16,1
ES-ALU-A	5,8	5,1	11,6	9,9
ES-ALU-V	16,7	14,0	21,7	20,4
ES-INOX-E	9,8	6,1	24,6	23,4
ES-ALU-A	13,1	9,0	24,2	23,1
ES-ALU-V	12,6	9,9	24,9	24,0
ES-INOX-E	8,5	4,2	25,4	23,3
ES-ALU-A	24,5	21,8	25,1	22,3
ES-ALU-V	16,9	13,2	23,6	18,0

Where:

F_m = mean values; F_c = characteristic values giving 75% confidence that 95% of results will be higher than this value.

(*) Bracket not tested. Minimum value is considered.

3.11 Mechanical characteristic of subframe fixings

Shear load strength of subframe fixings has been tested (see table 3.6).

Tensile strength of subframe fixing at least meets the values given in table 3.6 for pull-out resistance.

3.12 Corrosion

The GR-PL fixing devices are made of stainless steel 1.4307 or 1.4404 according to EN 10088. In addition, subframe drilling screws are made of stainless steel, quality A2 or A4 according to EN ISO 3506.

Therefore, the GR-PL fixing devices and subframe screws may be used in dry internal conditions or exposure in permanent damp internal conditions and also in external atmospheric exposure with high category of corrosivity of the atmosphere (including industrial and marine environment, C4 as defined in ISO 9223), if no particular aggressive conditions exist. Such particular aggressive conditions are e.g. permanent or alternating immersion in seawater or the splash zone of seawater, chloride atmosphere of indoor swimming pools or atmosphere with extreme chemical pollution (e.g. in desulphurization plants or road tunnels where de-icing materials are used).

The profiles and ES-ALU brackets are made of aluminum alloy AW 6005A EP/O T6 according to EN 573, EN 1999 and EN 755. The durability is class B and the minimum thickness is 3,0 mm. Therefore, these components may be used in the following external atmospheric exposure: rural environment, moderate industrial/urban environment, but excluding industrial marine environment. These components may be used in other external atmospheric conditions exposure if the components are protected as indicated in EN 1999-1-1.

ES-INOX brackets are made of stainless steel 1.4307 according to EN 10088, Therefore, these brackets may be used in dry internal conditions or exposure in permanent damp internal conditions and also in external atmospheric exposure with high category of corrosivity of the atmosphere (including industrial and marine environment, C4 as defined in ISO 9223), if no particular aggressive conditions exist. Such particular aggressive conditions are e.g. permanent or alternating immersion in seawater or the splash zone of seawater, chloride atmosphere of indoor swimming pools or atmosphere with extreme chemical pollution (e.g. in desulphurization plants or road tunnels where de-icing materials are used).

In addition, special attention should be considered in order to prevent the possible galvanic corrosion.

4 Assessment and verification of constancy of performance (hereinafter AVCP) system applied, with reference to its legal base

According to the decision 2003/640/EC, as amended of the European Commission⁷, the systems of AVCP (see EC delegated regulation (EU) No 568/2014 amending Annex V to Regulation (EU) 305/2011) given in the following table apply.

Table 4.1: Applicable AVPC system.

Product	Intended use	Level or class	System
Subframe and fixing kits for fastening cladding and external wall elements	External finishes of walls	Any	2+
	For uses subject to regulations on reaction to fire	A1	4

⁷ 2003/640/EC – Commission Decision of date 4 September 2003, published in the Official Journal of the European Union (OJEU) L226/21 of 10/09/2003.

5 Technical details necessary for the implementation of the AVCP system, as foreseen in the applicable EAD

All the necessary technical details for the implementation of the AVCP system are laid down in the *Control Plan* deposited with the ITeC⁸, with which the factory production control shall be in accordance.

Issued in Barcelona on 4 September 2019
by the Catalonia Institute of Construction Technology.

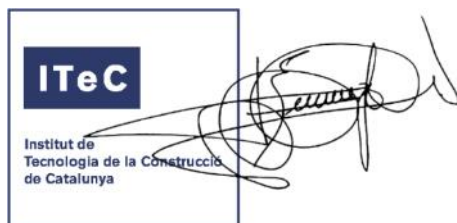

Ferran Bermejo Nualart
Technical Director, ITeC

⁸ The *Control Plan* is a confidential part of the ETA and is only handed over to the notified certification body involved in the assessment and verification of constancy of performance.

ANNEX 1: PF-ALU-PL assembled system



Figure A1.1: PF-ALU-PL assembled system.

ANNEX 2: GR-PL fixing device

Geometry characteristics			
Form	GR-PL-46	Fixing device & Rail protector	Figures A2.1
	GR-PL-100		Figures A2.2
	GR-PL-100/2		Figures A2.3
<p>Figure A2.1: GR-PL-46 forms.</p>			
<p>Figure A2.2: GR-PL-100 forms.</p>			
<p>Figure A2.3: GR-PL-100/2 forms.</p>			
Dimensions	Fixing device	GR-PL-46	Figures A2.4
		GR-PL-100	Figures A2.5
		GR-PL-100/2	Figures A2.6
	Rail protector	GR-PL-46	Figures A2.7
		GR-PL-100	
		GR-PL-100/2	

Material properties		Values		Reference
GR-PL	Type of material	Stainless steel 1.4307 (X2CrNi18-9)	Stainless steel 1.4404 (X2CrNiMo17-12-2)	EN 10088-1
	Density (kg/m ³)	7900	8000	EN 10088-1
	Modulus of elasticity at 20 °C (MPa)	200000	200000	EN 10088-1
	Thermal expansion coefficient at 20 °C-100 °C (µm/m.°C)	16,0	16,0	EN 10088-1
	Elastic limit R _{p0.2} (MPa)	200	220	EN 10088-2
	Tensile strength R _m (MPa)	500-700	520-670	EN 10088-2
	Elongation A (%)	45	45	EN 10088-2
	Intergranular corrosion resistance at delivery conditions	Yes	Yes	EN 10088-2
Rail protectors	Type of material	Polyamide PA6		---

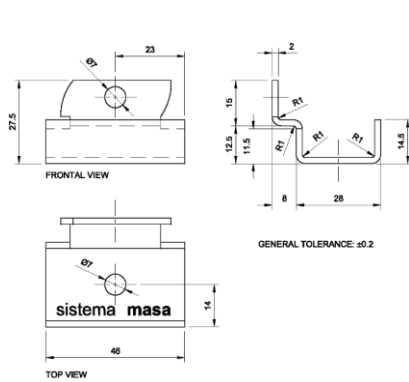

Figure A2.4a: GR-PL-46-S.

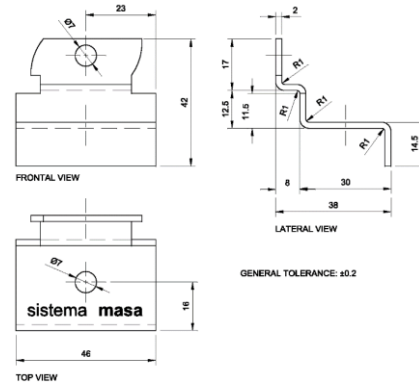

Figure A2.4b: GR-PL-46-I.

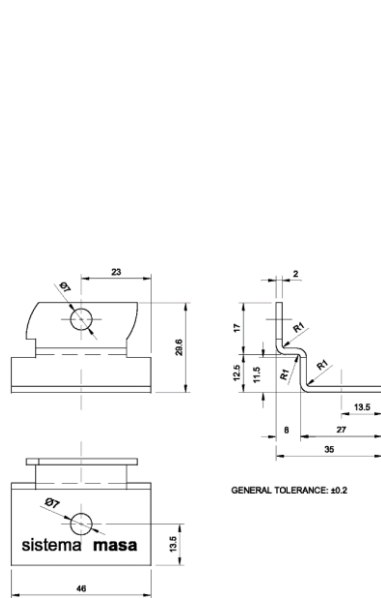

Figure A2.4c: GR-PL-46-TI.

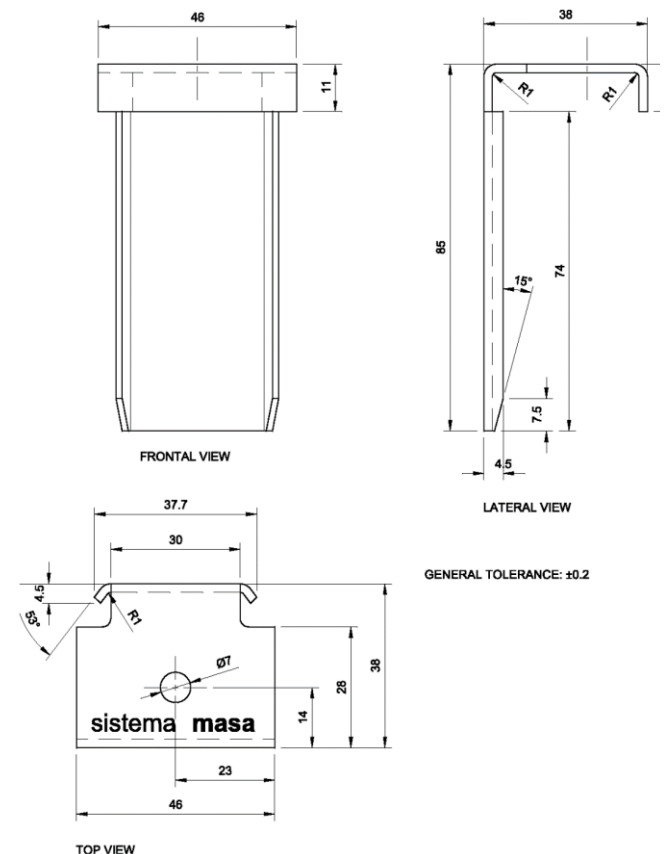

Figure A2.4d: GR-PL-46-TSE.

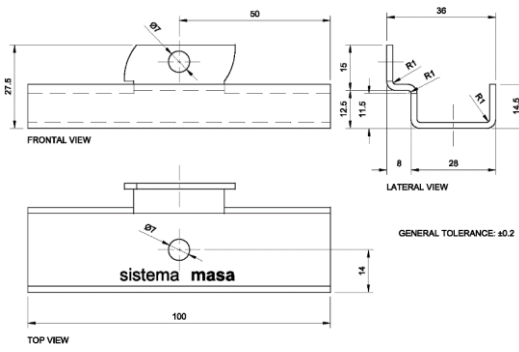

Figure A2.5a: GR-PL-100-S.

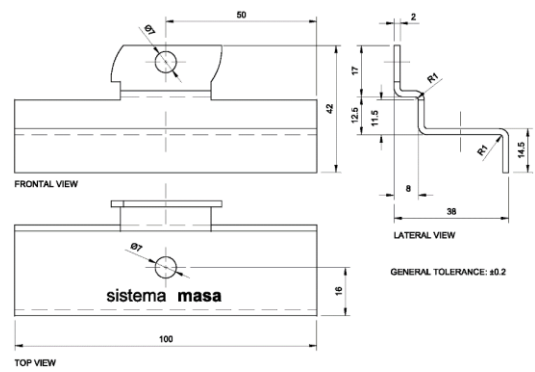

Figure A2.5b: GR-PL-100-I.

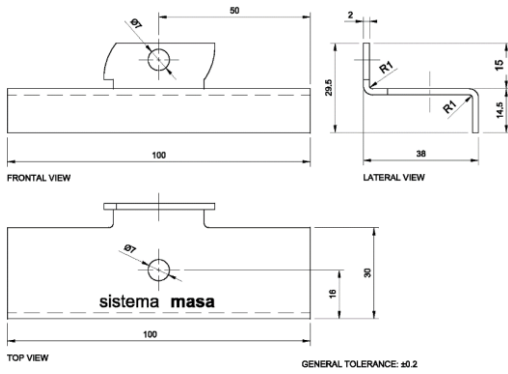

Figure A2.5c: GR-PL-100-SC.

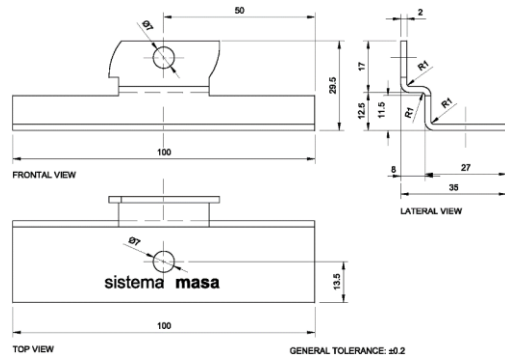

Figure A2.5d: GR-PL-100-TI.

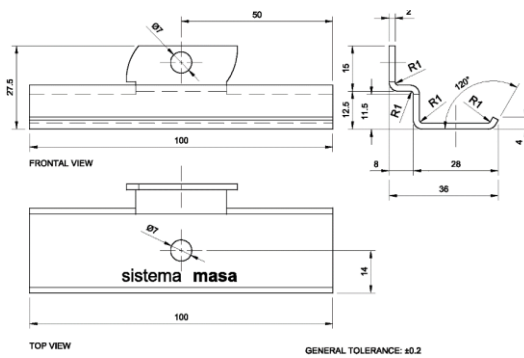

Figure A2.5e: GR-PL-100-TI 90°.

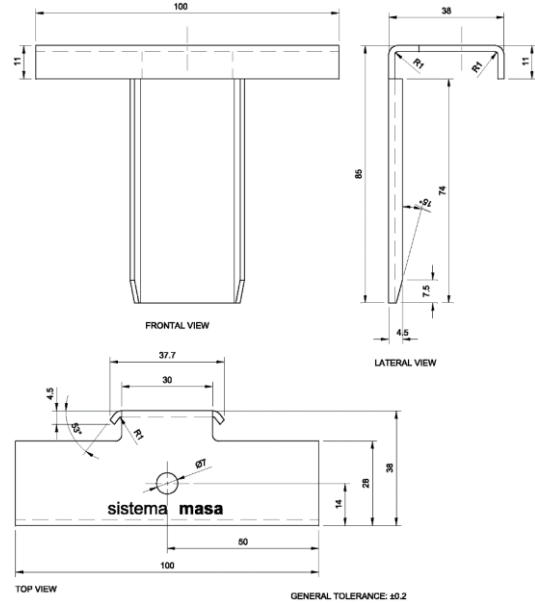

Figure A2.5f: GR-PL-100-TSE.

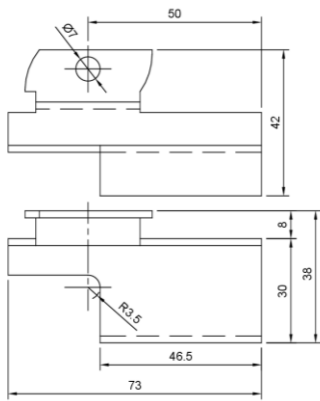

Figure A2.6a: GR-PL-100-I/2.

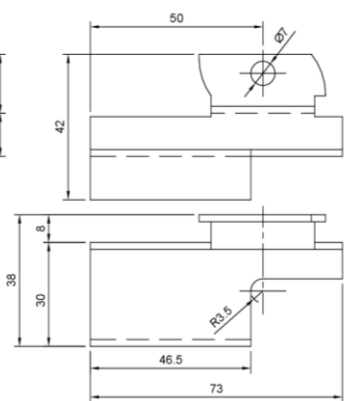
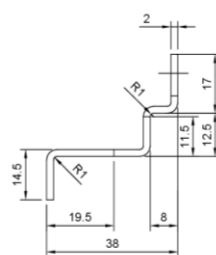
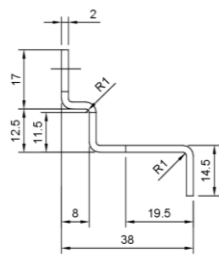

Figure A2.6b: GR-PL-100-I-I/2.

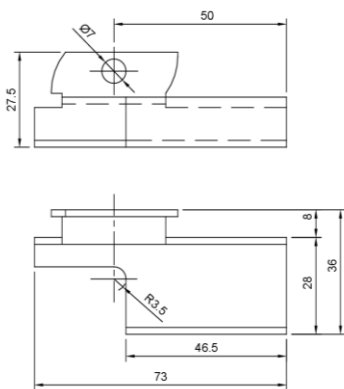

Figure A2.6c: GR-PL-100-S/2.

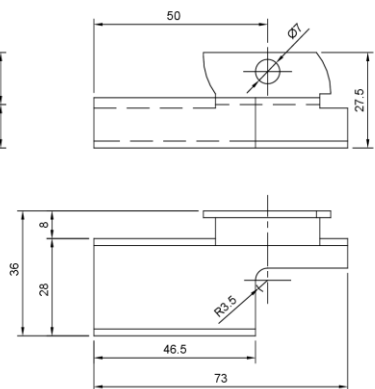
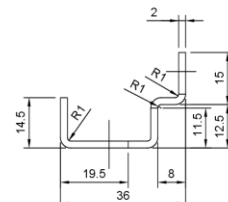
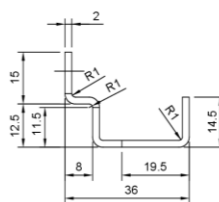

Figure A2.6d: GR-PL-100-S-I/2.

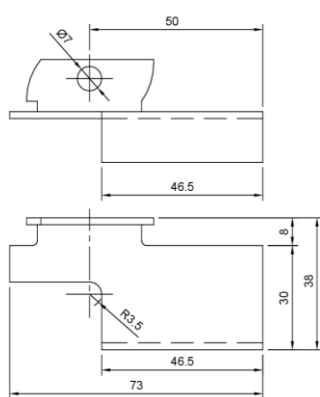

Figure A2.6e: GR-PL-100-T-S-C/2.

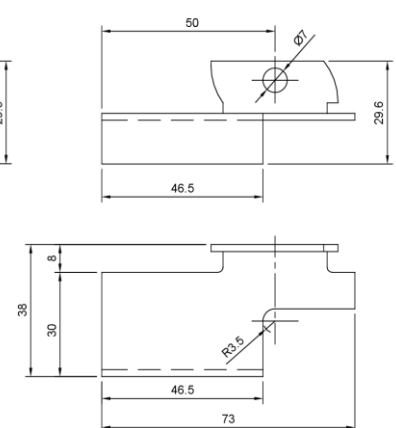
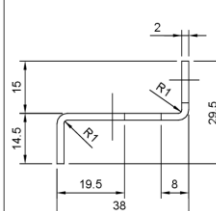
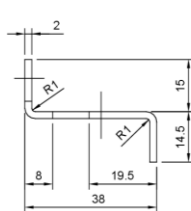

Figure A2.6f: GR-PL-100-T-S-C-I/2.

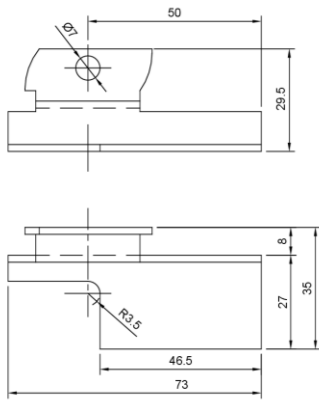

Figure A2.6g: GR-PL-100-T-I/2.

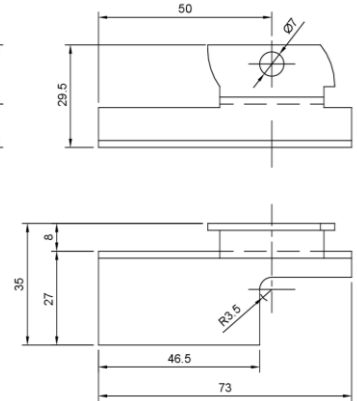
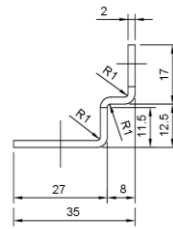
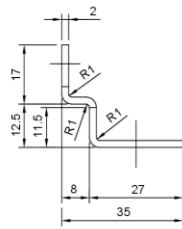

Figure A2.6h: GR-PL-100-T-I-I/2.

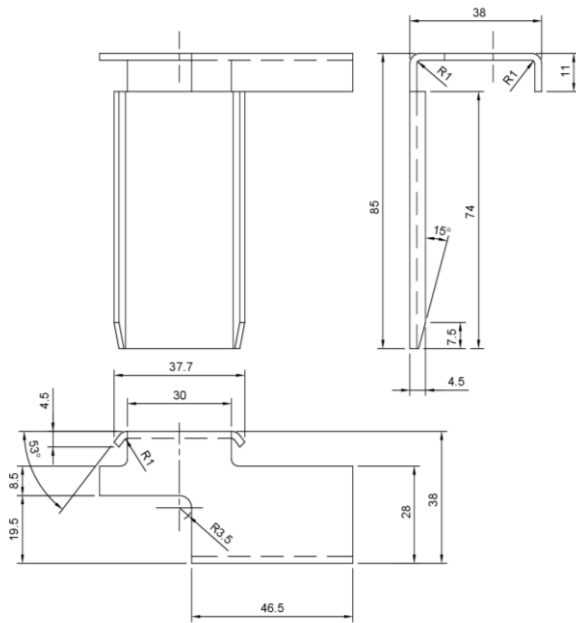

Figure A2.6i: GR-PL-100-TSE/2.

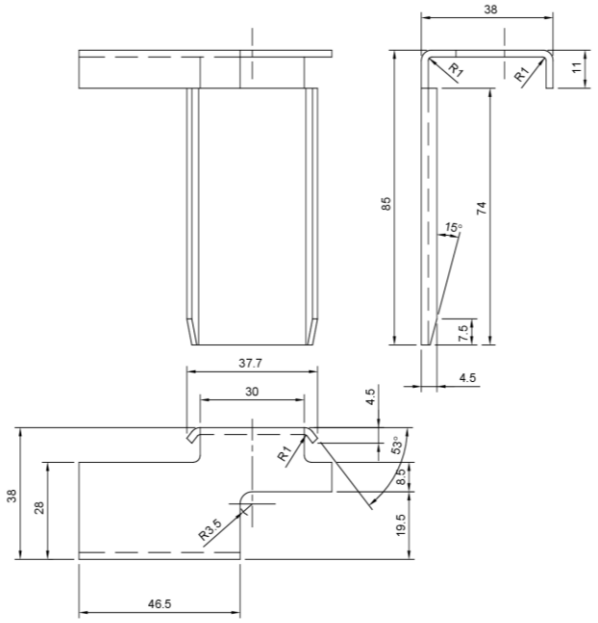

Figure A2.6j: GR-PL-100-TSE-I/2.

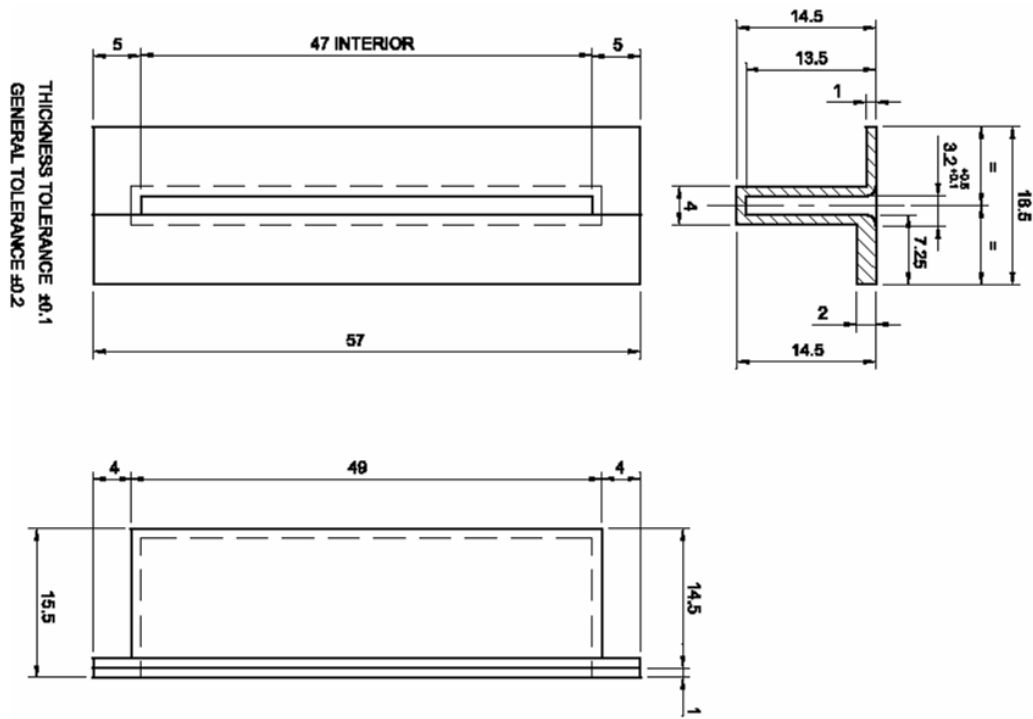

Figure A2.7a: GR-PL-46 & GR-PL-100/2 Rail protector.

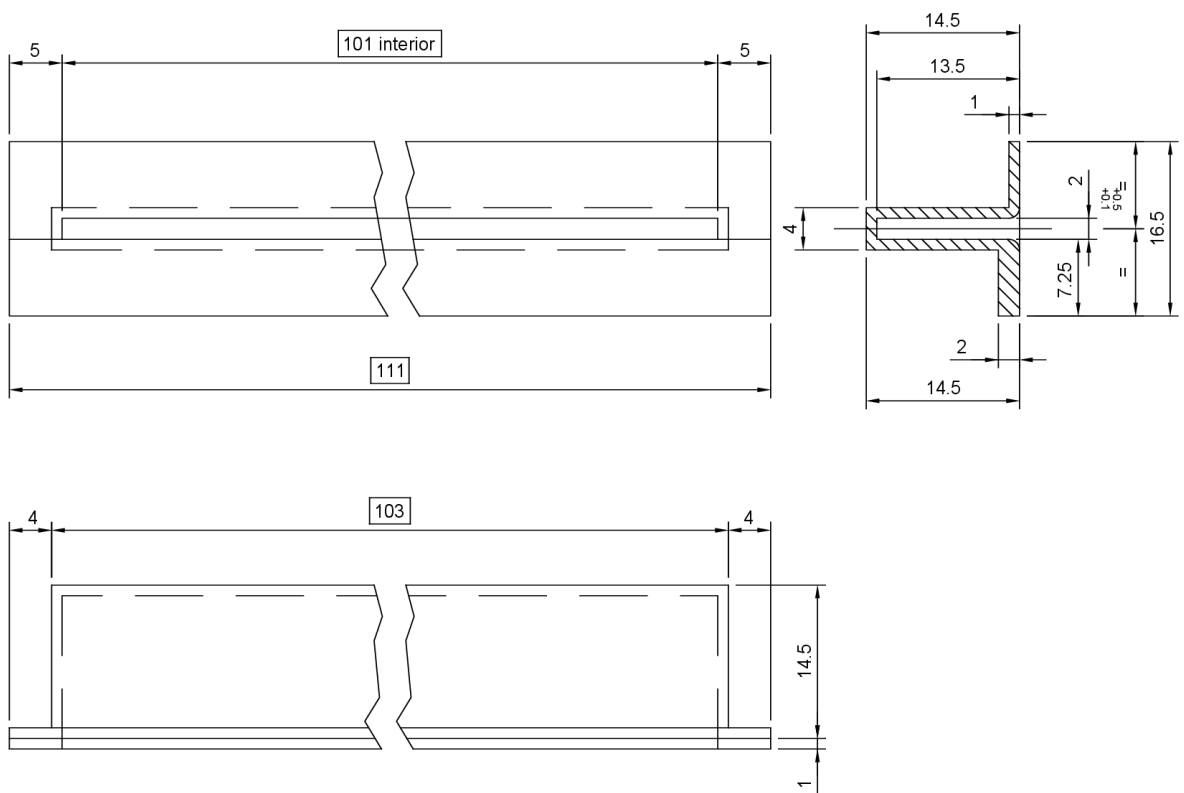



Figure A2.7b: GR-PL-100 Rail protector.

ANNEX 3: Subframe profiles

Geometry characteristics							
PF-AL-U-40							
PF-AL-U-60							
PF-AL-U-80							
PF-AL-U-100							
Form							
PF-AL-T-60							
PF-AL-T-80							
Dimensions	dx (mm)	dy (mm)	L (mm)	L1 (mm)	L2 (mm)	Tolerances (mm)	
PF-AL-U-40	19,8	18,4	40	24,1	15,9	± 0,15	Figure A3.1
PF-AL-U-60	29,4	16,7	60	32,6	24,4	± 0,15	
PF-AL-U-80	41,0	15,0	80	43,2	35,0	± 0,15	
PF-AL-U-100	51,3	14,5	100	54,1	45,9	± 0,15	
PF-AL-T-60	22,5	28,3	57	24,4	32,6	± 0,15	Figure A3.2
PF-AL-T-80	22,6	39,4	78,2	35,0	43,2	± 0,15	
Ancillary profiles between vertical profiles			EUP-ALU-40		Figure A3.3		
			EUP-ALU-60		Figure A3.4		
			EUP-ALU-80		Figure A3.5		
			EUP-ALU-100		Figure A3.6		
			EUP-AL-T-60		Figure A3.7		
EUP-AL-T-80							
Ancillary profiles for verticality lack			ES-AL-O-20		Figure A3.8		
			ES-AL-O-40				
Inertia of profile section (cm⁴)		I_{xx} (cm⁴)		I_{yy} (cm⁴)			
PF-AL-U-40		9,1		10,8			
PF-AL-U-60		22,5		12,2			
PF-AL-U-80		49,3		13,5			
PF-AL-U-100		94,1		16,3			
PF-AL-T-60		25,2		19,8			
PF-AL-T-80		57,4		25,5			

Material properties	Values	Reference
Type of material	Aluminium alloy EN AW-6005A EP/O T6	EN 1999-1-1
Durability class	Class B	EN 1999-1-1
Density (kg/m ³)	2700	EN 1999-1-1
Modulus of elasticity (MPa)	70000	EN 1999-1-1
Thermal expansion coefficient (µm/m·°C)	23,0	EN 1999-1-1
Elastic limit R _{p0,2} (MPa)	225	EN 755-2 & EN 1999-1-1
Tensile strength R _m (MPa)	270	EN 755-2 & EN 1999-1-1
Elongation A (%)	8	EN 755-2 & EN 1999-1-1
Poisson's coefficient	0,3	EN 1999-1-1
Modulus of transversal elasticity, G (MPa)	27000	EN 1999-1-1

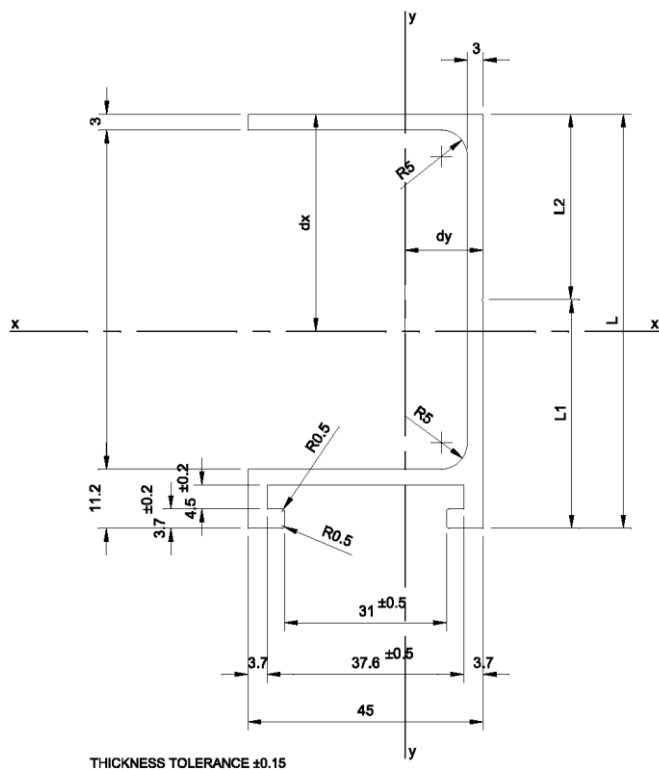

Figure A3.1: Profile PF-AL-U.

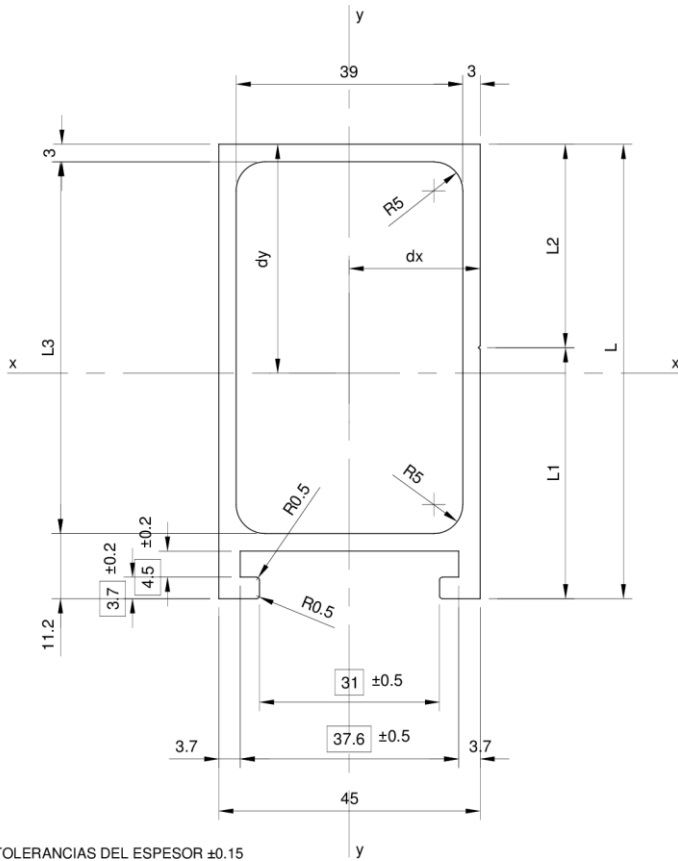

Figure A3.2: Profile PF-AL-T.

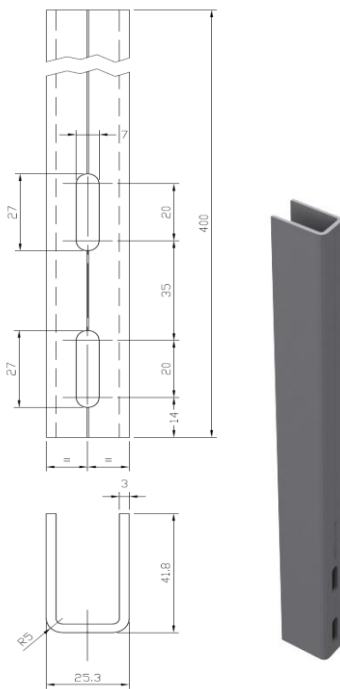

Figure A3.3: Ancillary profile EUP-ALU-40.

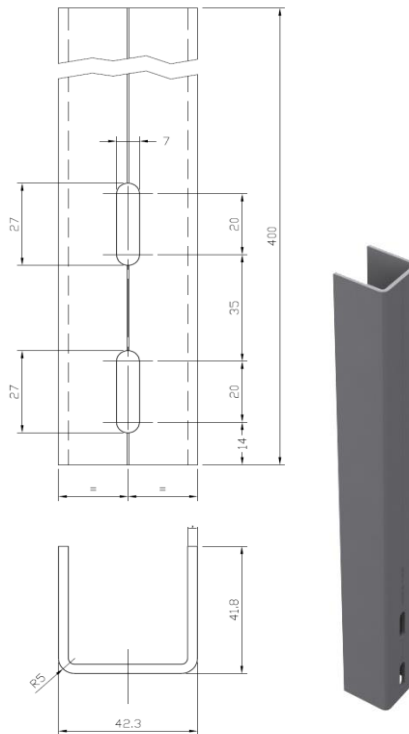

Figure A3.4: Ancillary profile EUP-ALU-60.

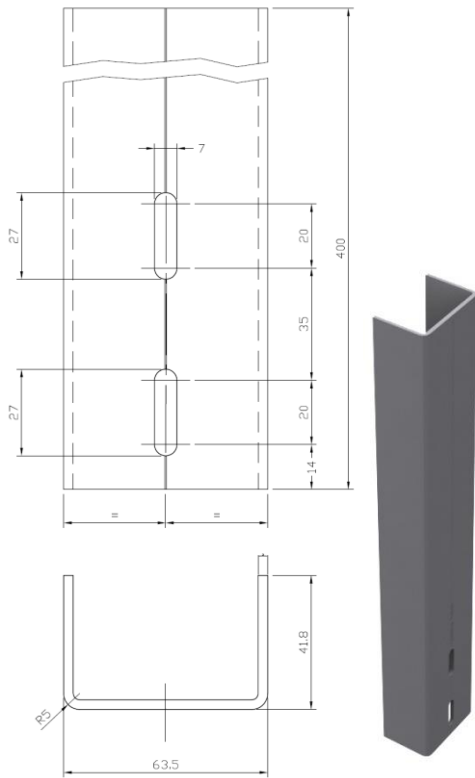

Figure A3.5: Ancillary profile EUP-ALU-80.

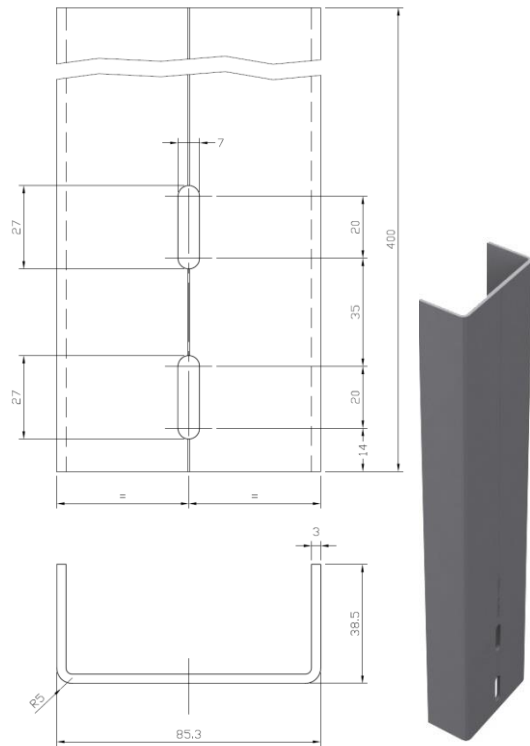

Figure A3.6: Ancillary profile EUP-ALU-100.

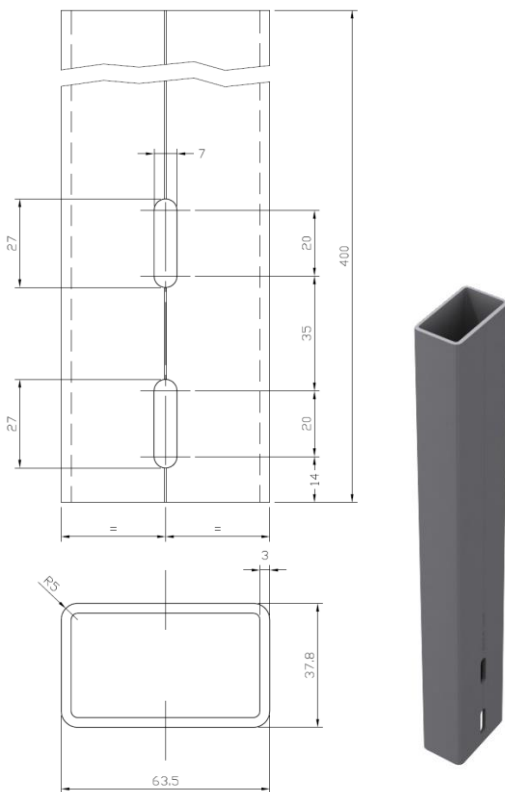
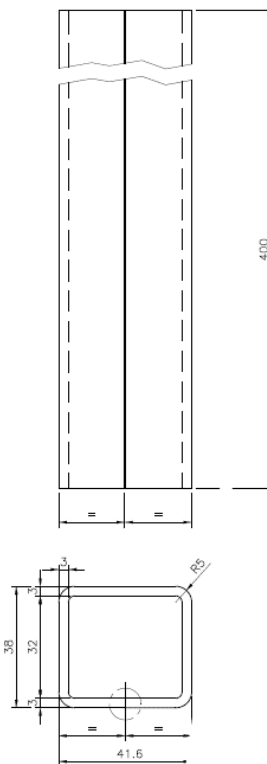

Figure A3.7: Ancillary profile EUP-ALU-T.



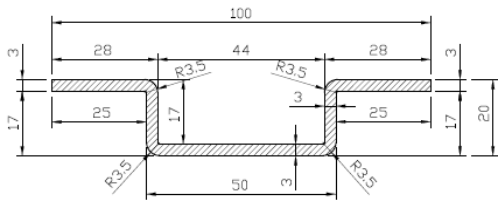

Figure A3.8: Ancillary profile ES-AL-O-20.

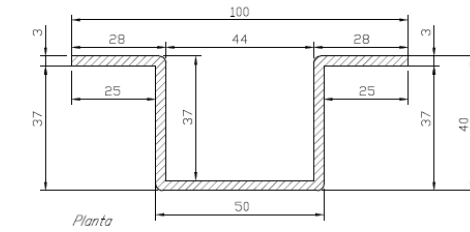
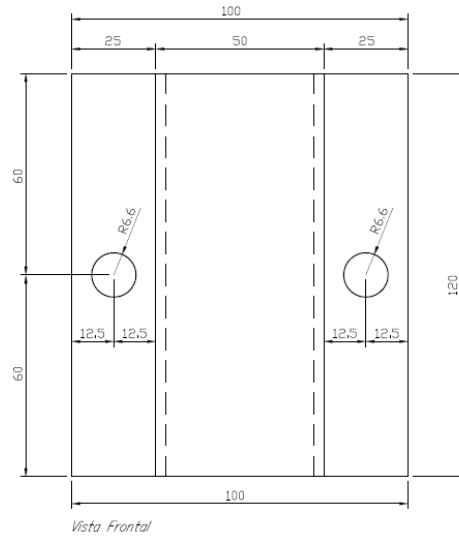





Figure A3.9: Ancillary profile ES-AL-O-40.



ANNEX 4: Subframe brackets

A4.1. Aluminium brackets

Geometry characteristics																																																																																																																																													
Form	ES-ALU-A & ES-ALU-V	45/100	 ES-ALU-A	 ES-ALU-V																																																																																																																																									
		67/100																																																																																																																																											
87/100																																																																																																																																													
117/100																																																																																																																																													
148/100																																																																																																																																													
177/100																																																																																																																																													
208/100																																																																																																																																													
238/100																																																																																																																																													
267/100																																																																																																																																													
Form	ES-ALU-E	67/200			 ES-ALU-E																																																																																																																																								
		87/200																																																																																																																																											
		117/200																																																																																																																																											
		148/200																																																																																																																																											
		177/200																																																																																																																																											
		208/200																																																																																																																																											
		238/200																																																																																																																																											
		267/200																																																																																																																																											
		<table border="1"> <thead> <tr> <th></th> <th></th> <th>L (mm)</th> <th>L1 (mm)</th> <th>Tolerances (mm)</th> <th></th> </tr> </thead> <tbody> <tr> <td rowspan="20">Dimensions (mm)</td> <td rowspan="10">ES-ALU-A</td> <td>45/100</td> <td>---</td> <td>---</td> <td>± 0,15</td> <td>Figure A4.1</td> </tr> <tr> <td>67/100</td> <td>---</td> <td>---</td> <td>± 0,15</td> <td>Figure A4.2</td> </tr> <tr> <td>87/100</td> <td>---</td> <td>---</td> <td>± 0,15</td> <td>Figure A4.3</td> </tr> <tr> <td>117/100</td> <td>117</td> <td rowspan="4">31</td> <td>± 0,15</td> <td rowspan="4">Figure A4.4</td> </tr> <tr> <td>148/100</td> <td>148</td> <td>± 0,15</td> </tr> <tr> <td>177/100</td> <td>177</td> <td>± 0,15</td> </tr> <tr> <td>208/100</td> <td>208</td> <td>± 0,15</td> </tr> <tr> <td>238/100</td> <td>---</td> <td>---</td> <td>± 0,15</td> <td>Figure A4.5</td> </tr> <tr> <td>267/100</td> <td>---</td> <td>---</td> <td>± 0,15</td> <td>Figure A4.6</td> </tr> <tr> <td rowspan="10">ES-ALU-V</td> <td>45/100</td> <td>---</td> <td>---</td> <td>± 0,15</td> <td>Figure A4.7</td> </tr> <tr> <td>67/100</td> <td>---</td> <td>---</td> <td>± 0,15</td> <td>Figure A4.8</td> </tr> <tr> <td>87/100</td> <td>---</td> <td>---</td> <td>± 0,15</td> <td>Figure A4.9</td> </tr> <tr> <td>117/100</td> <td>117</td> <td rowspan="4">31</td> <td>± 0,15</td> <td rowspan="4">Figure A4.10</td> </tr> <tr> <td>148/100</td> <td>148</td> <td>± 0,15</td> </tr> <tr> <td>177/100</td> <td>177</td> <td>± 0,15</td> </tr> <tr> <td>208/100</td> <td>208</td> <td>± 0,15</td> </tr> <tr> <td>238/100</td> <td>---</td> <td>---</td> <td>± 0,15</td> <td>Figure A4.11</td> </tr> <tr> <td>267/100</td> <td>---</td> <td>---</td> <td>± 0,15</td> <td>Figure A4.12</td> </tr> <tr> <td rowspan="7">ES-ALU-E</td> <td>67/200</td> <td>---</td> <td>---</td> <td>± 0,15</td> <td>Figure A4.13</td> </tr> <tr> <td>87/200</td> <td>---</td> <td>---</td> <td>± 0,15</td> <td>Figure A4.14</td> </tr> <tr> <td>117/200</td> <td>117</td> <td rowspan="4">31</td> <td>± 0,15</td> <td rowspan="4">Figure A4.15</td> </tr> <tr> <td>148/200</td> <td>148</td> <td>± 0,15</td> </tr> <tr> <td>177/200</td> <td>177</td> <td>± 0,15</td> </tr> <tr> <td>208/200</td> <td>208</td> <td>± 0,15</td> </tr> <tr> <td>238/200</td> <td>---</td> <td>---</td> <td>± 0,15</td> <td>Figure A4.16</td> </tr> <tr> <td>267/200</td> <td>---</td> <td>---</td> <td>± 0,15</td> <td>Figure A4.17</td> </tr> <tr> <td rowspan="2">Ancillary thermal bridge break piece</td> <td>Termostop 100</td> <td>---</td> <td>---</td> <td>--</td> <td>Figure A4.20a</td> </tr> <tr> <td>Termostop 200</td> <td>---</td> <td>---</td> <td>--</td> <td>Figure A4.20b</td> </tr> </tbody> </table>								L (mm)	L1 (mm)	Tolerances (mm)		Dimensions (mm)	ES-ALU-A	45/100	---	---	± 0,15	Figure A4.1	67/100	---	---	± 0,15	Figure A4.2	87/100	---	---	± 0,15	Figure A4.3	117/100	117	31	± 0,15	Figure A4.4	148/100	148	± 0,15	177/100	177	± 0,15	208/100	208	± 0,15	238/100	---	---	± 0,15	Figure A4.5	267/100	---	---	± 0,15	Figure A4.6	ES-ALU-V	45/100	---	---	± 0,15	Figure A4.7	67/100	---	---	± 0,15	Figure A4.8	87/100	---	---	± 0,15	Figure A4.9	117/100	117	31	± 0,15	Figure A4.10	148/100	148	± 0,15	177/100	177	± 0,15	208/100	208	± 0,15	238/100	---	---	± 0,15	Figure A4.11	267/100	---	---	± 0,15	Figure A4.12	ES-ALU-E	67/200	---	---	± 0,15	Figure A4.13	87/200	---	---	± 0,15	Figure A4.14	117/200	117	31	± 0,15	Figure A4.15	148/200	148	± 0,15	177/200	177	± 0,15	208/200	208	± 0,15	238/200	---	---	± 0,15	Figure A4.16	267/200	---	---	± 0,15	Figure A4.17	Ancillary thermal bridge break piece	Termostop 100	---	---	--	Figure A4.20a	Termostop 200	---	---	--	Figure A4.20b	
				L (mm)		L1 (mm)	Tolerances (mm)																																																																																																																																						
Dimensions (mm)	ES-ALU-A	45/100	---	---	± 0,15	Figure A4.1																																																																																																																																							
		67/100	---	---	± 0,15	Figure A4.2																																																																																																																																							
		87/100	---	---	± 0,15	Figure A4.3																																																																																																																																							
		117/100	117	31	± 0,15	Figure A4.4																																																																																																																																							
		148/100	148		± 0,15																																																																																																																																								
		177/100	177		± 0,15																																																																																																																																								
		208/100	208		± 0,15																																																																																																																																								
		238/100	---	---	± 0,15	Figure A4.5																																																																																																																																							
		267/100	---	---	± 0,15	Figure A4.6																																																																																																																																							
		ES-ALU-V	45/100	---	---	± 0,15	Figure A4.7																																																																																																																																						
	67/100		---	---	± 0,15	Figure A4.8																																																																																																																																							
	87/100		---	---	± 0,15	Figure A4.9																																																																																																																																							
	117/100		117	31	± 0,15	Figure A4.10																																																																																																																																							
	148/100		148		± 0,15																																																																																																																																								
	177/100		177		± 0,15																																																																																																																																								
	208/100		208		± 0,15																																																																																																																																								
	238/100		---	---	± 0,15	Figure A4.11																																																																																																																																							
	267/100		---	---	± 0,15	Figure A4.12																																																																																																																																							
	ES-ALU-E		67/200	---	---	± 0,15	Figure A4.13																																																																																																																																						
		87/200	---	---	± 0,15	Figure A4.14																																																																																																																																							
117/200		117	31	± 0,15	Figure A4.15																																																																																																																																								
148/200		148		± 0,15																																																																																																																																									
177/200		177		± 0,15																																																																																																																																									
208/200		208		± 0,15																																																																																																																																									
238/200		---	---	± 0,15	Figure A4.16																																																																																																																																								
267/200	---	---	± 0,15	Figure A4.17																																																																																																																																									
Ancillary thermal bridge break piece	Termostop 100	---	---	--	Figure A4.20a																																																																																																																																								
	Termostop 200	---	---	--	Figure A4.20b																																																																																																																																								

Material properties	Values	Reference
Type of material	Aluminium alloy EN AW-6005A EP/O T6	EN 1999-1-1
Durability class	Class B	EN 1999-1-1
Density (kg/m ³)	2700	EN 1999-1-1
Modulus of elasticity (MPa)	70000	EN 1999-1-1
Thermal expansion coefficient (µm/m °C)	23,0	EN 1999-1-1
Elastic limit R _{p0,2} (MPa)	225	EN 755-2 & EN 1999-1-1
Tensile strength R _m (MPa)	270	EN 755-2 & EN 1999-1-1
Elongation A (%)	8	EN 755-2 & EN 1999-1-1
Poisson's coefficient	0,3	EN 1999-1-1
Modulus of transversal elasticity, G (MPa)	27000	EN 1999-1-1

A4.2. Stainless steel brackets

Geometry characteristics						
ES-INOX-A	238/100		ES-INOX-A			
	267/100					
	296/100					
	325/100					
ES-INOX-E	238/200		ES-INOX-E			
	267/200					
	296/200					
	325/200					
Dimensions (mm)		L (mm)	L1 (mm)	Tolerances (mm)		
	ES-INOX-A	238/100	238	128	± 0,15	Figure A4.18
		267/100	267	157		
		296/100	296	186		
		325/100	325	215		
	ES-INOX-E	238/200	238	128	± 0,15	Figure A4.19
		267/200	267	157		
		296/200	296	186		
		325/200	325	215		

Material properties	Values	Reference
Type of material	Stainless steel 1.4307 (X2CrNi18-9)	EN 10088-1
Density (kg/m ³)	7900	EN 10088-1
Modulus of elasticity at 20 °C (MPa)	200000	EN 10088-1
Thermal expansion coefficient at 20 °C-100 °C (µm/m.°C)	16,0	EN 10088-1
Elastic limit R _{p0,2} (MPa)	200	EN 10088-2
Tensile strength R _m (MPa)	500-700	EN 10088-2
Elongation A (%)	45	EN 10088-2
Intergranular corrosion resistance at delivery conditions	Yes	EN 10088-2

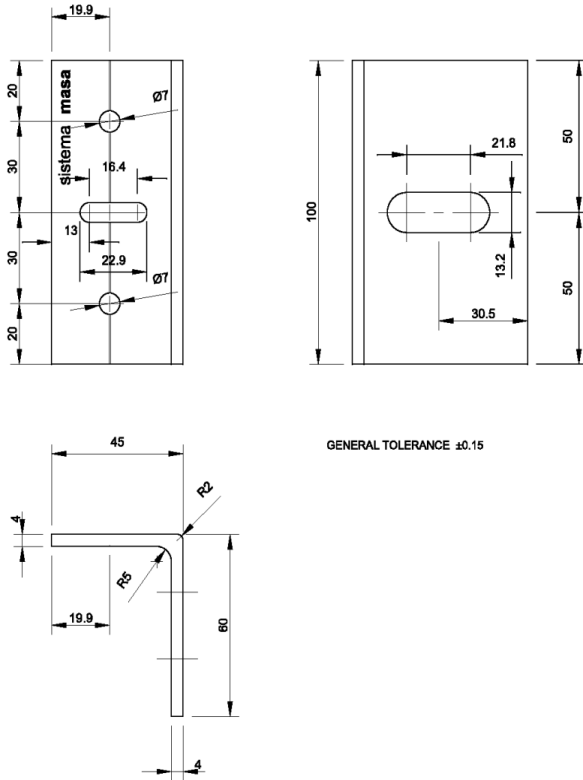

Figure A4.1: Brackets ES-ALU-45/100-A.

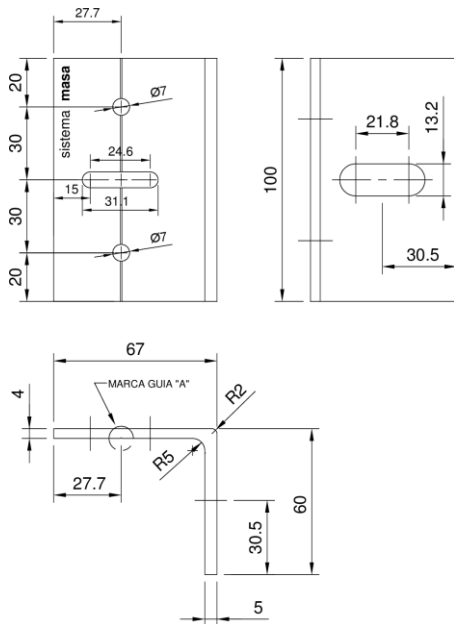

Figure A4.2: Brackets ES-ALU-67/100-A.

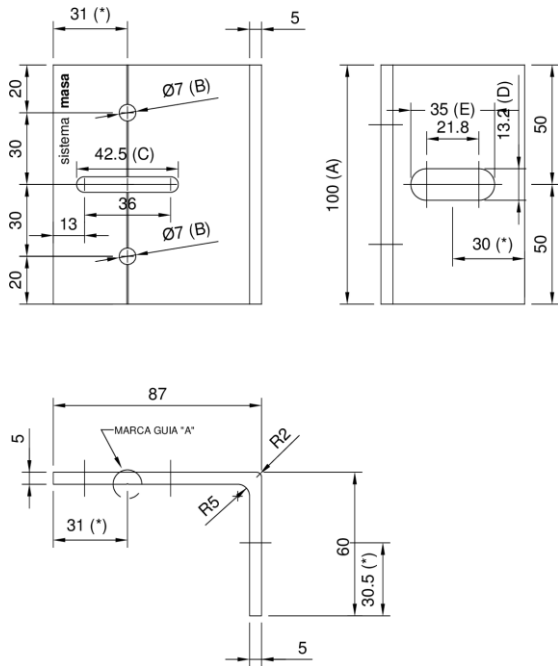

Figure A4.3: Brackets ES-ALU-87/100-A.

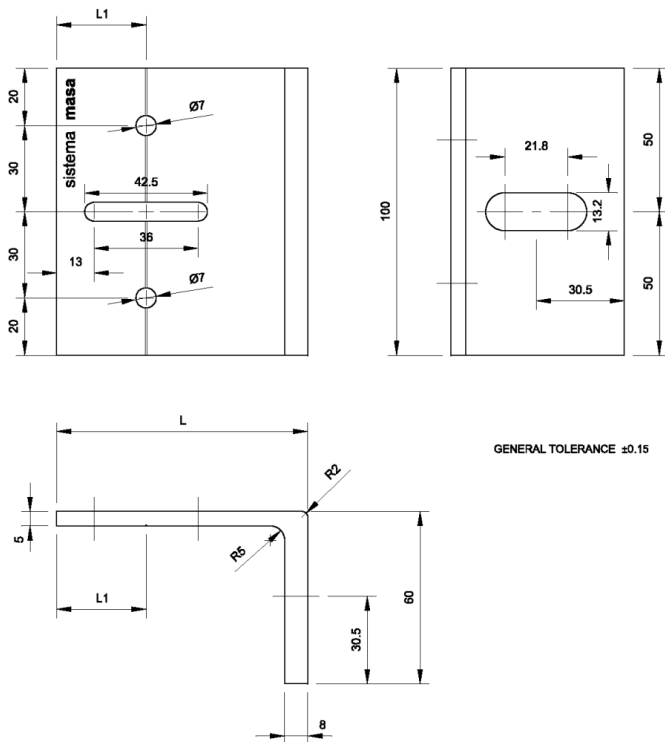

Figure A4.4: Brackets ES-ALU-(117/100; 148/100; 177/100 & 208/100)-A.

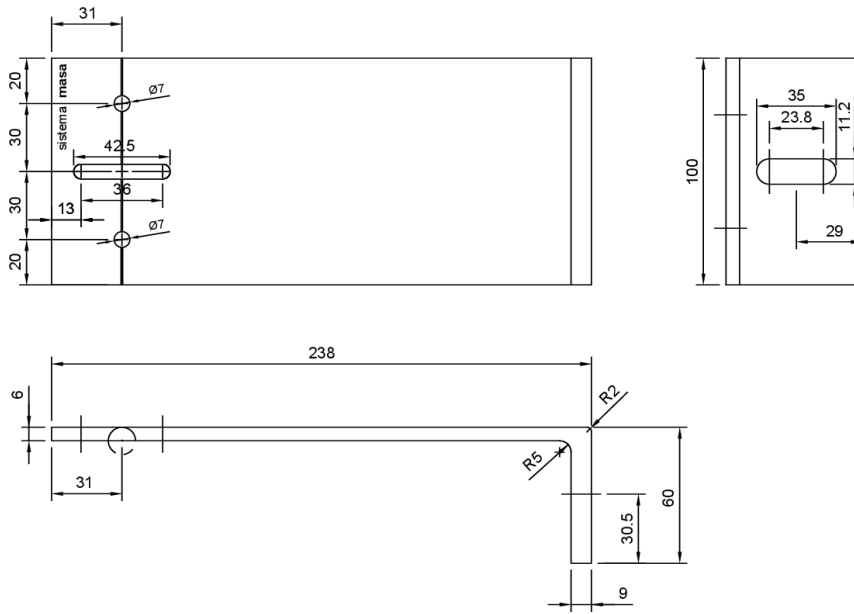

Figure A4.5: Brackets ES-ALU-238/100-A.

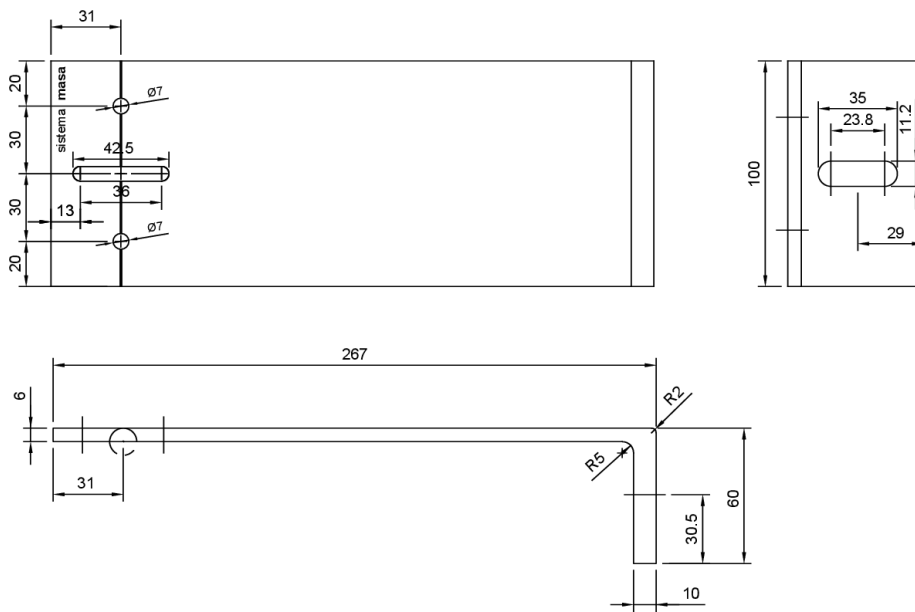

Figure A4.6: Brackets ES-ALU-267/100-A.

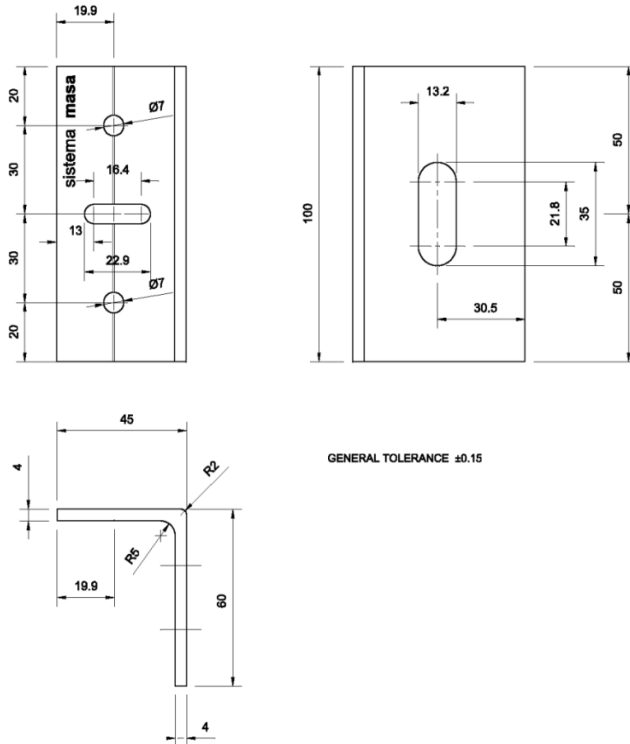

Figure A4.7: Brackets ES-ALU-45/100-V.

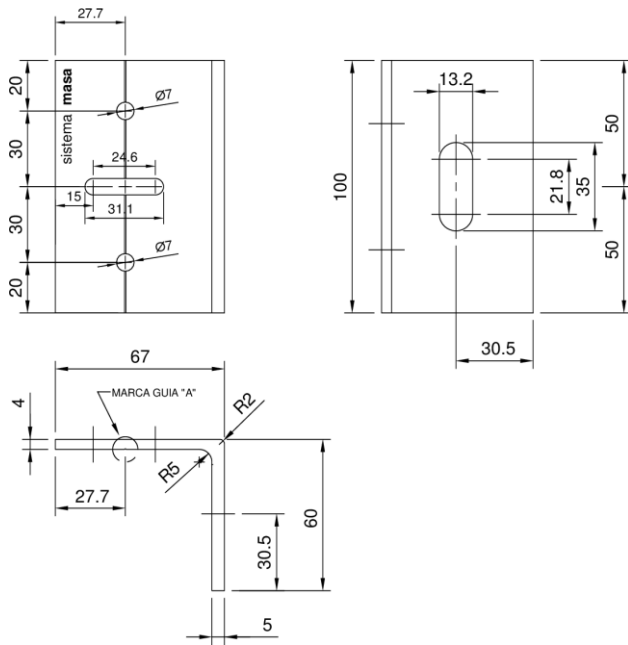

Figure A4.8: Brackets ES-ALU-67/100-V.

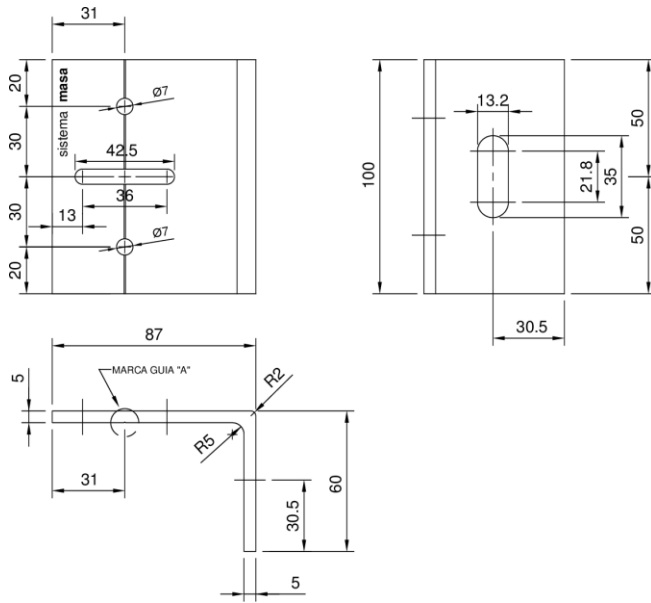

Figure A4.9: Brackets ES-ALU-87/100-V.

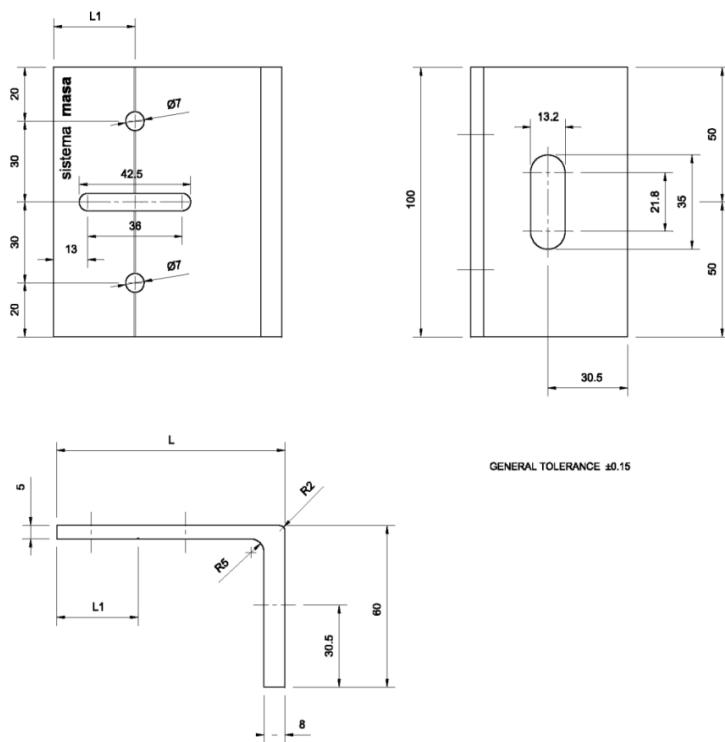

Figure A4.10: Brackets ES-ALU-(117/100; 148/100; 177/100 & 208/100)-V.

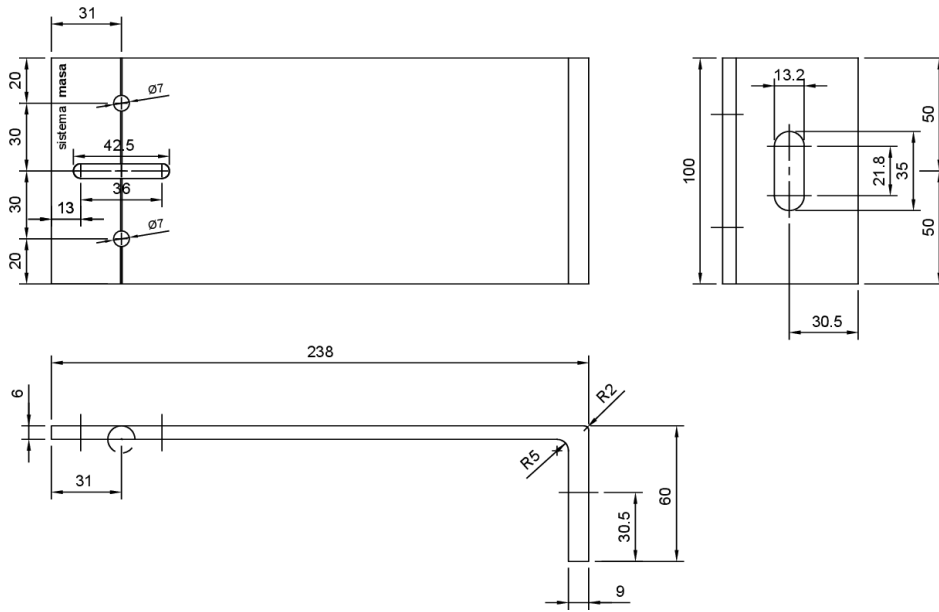

Figure A4.11: Brackets ES-ALU-238-V.

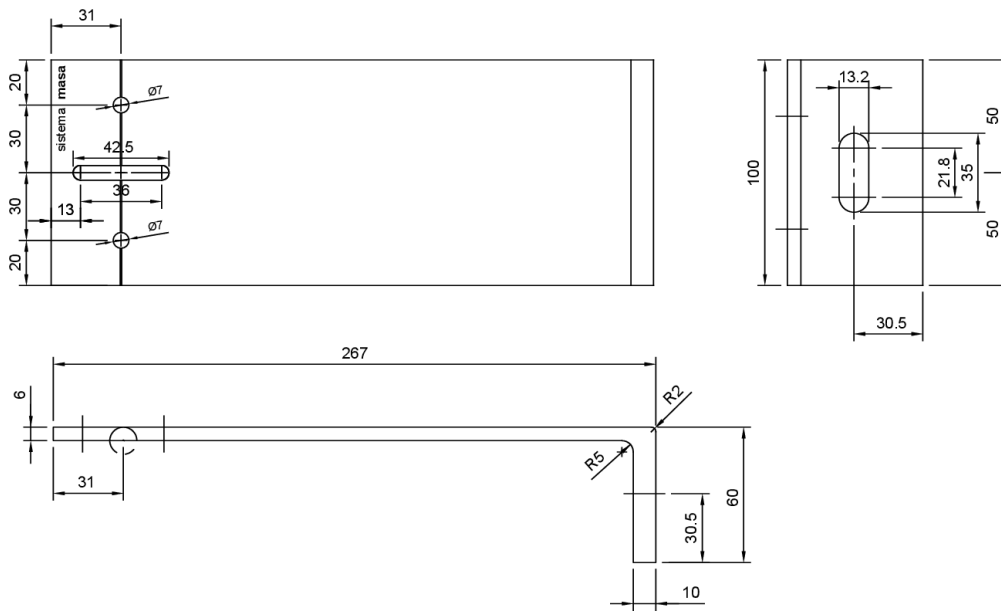

Figure A4.12: Brackets ES-ALU-267-V.

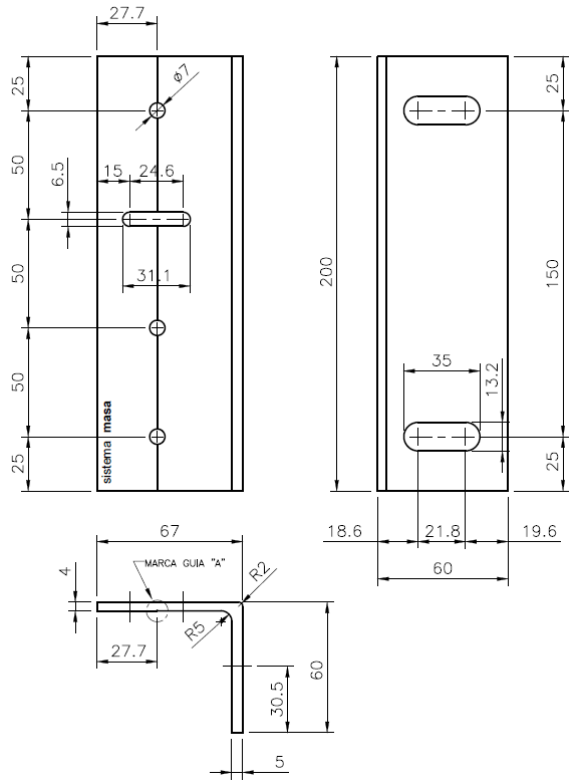

Figure A4.13: Brackets ES-ALU-67/200-E.

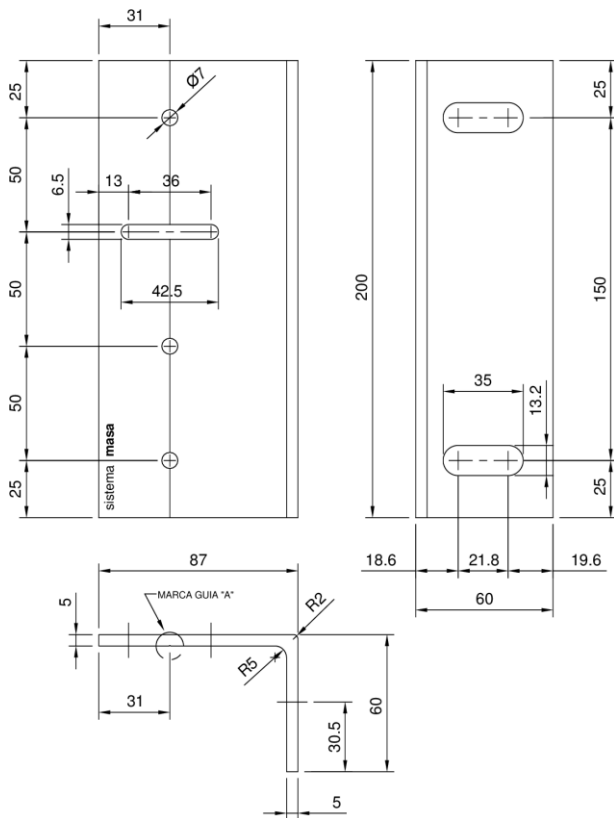

Figure A4.14: Brackets ES-ALU-87/200-E.

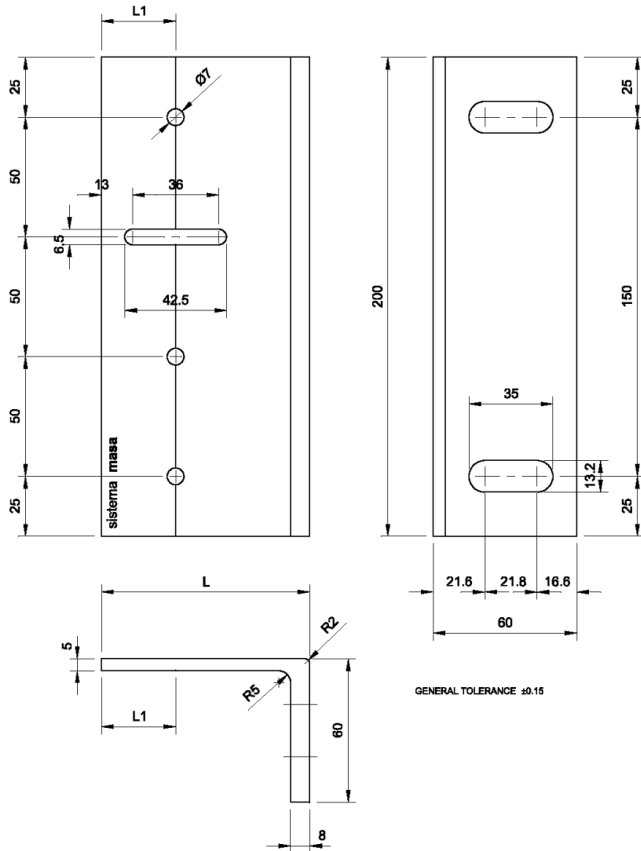

Figure A4.15: Brackets ES-ALU-(117/200; 148/200; 177/200 & 208/200)-E.

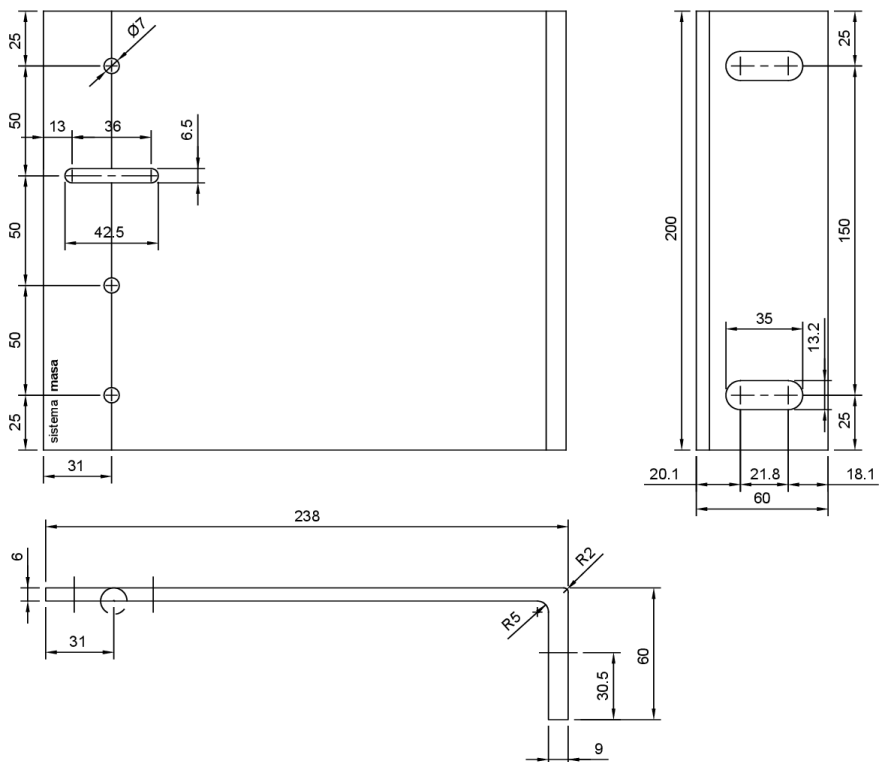

Figure A4.16: Brackets ES-ALU-238/200-E.

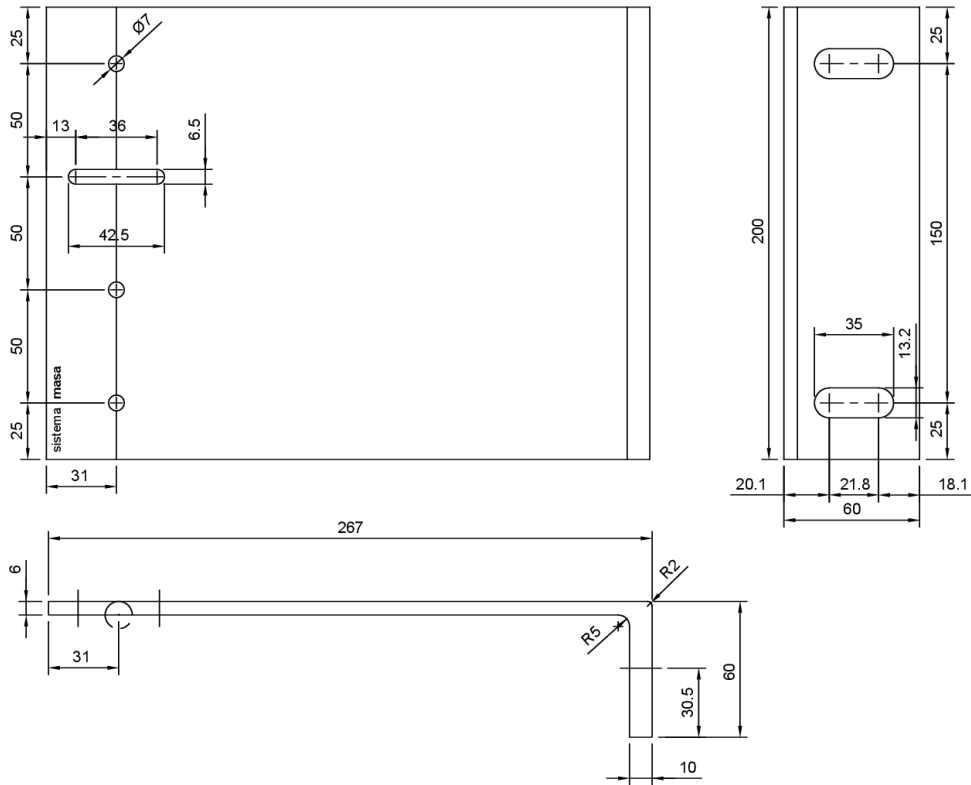

Figure A4.17: Brackets ES-ALU-267/200-E.

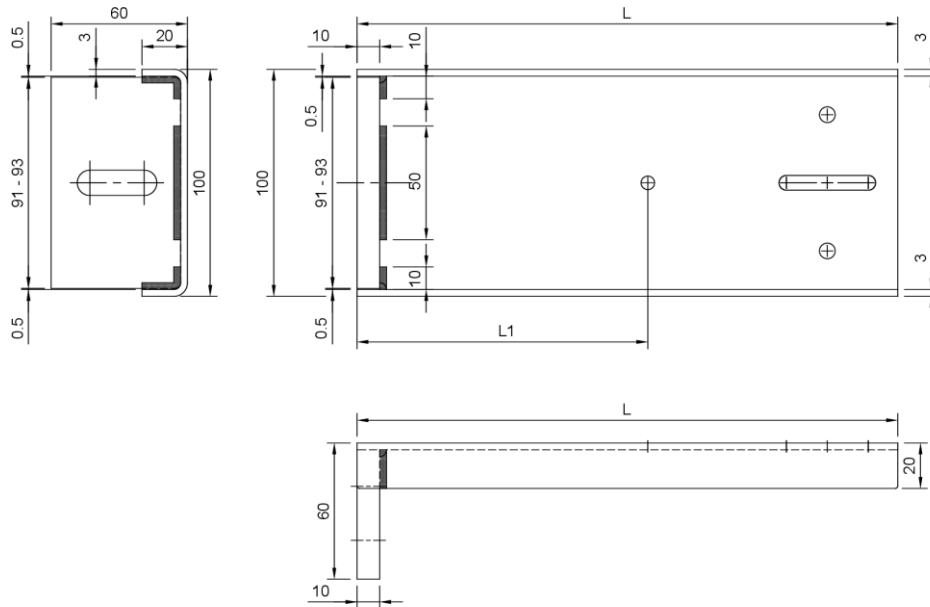

Figure A4.18: Brackets ES-INOX-(238/100; 267/100; 296/100 & 325/100)-A.

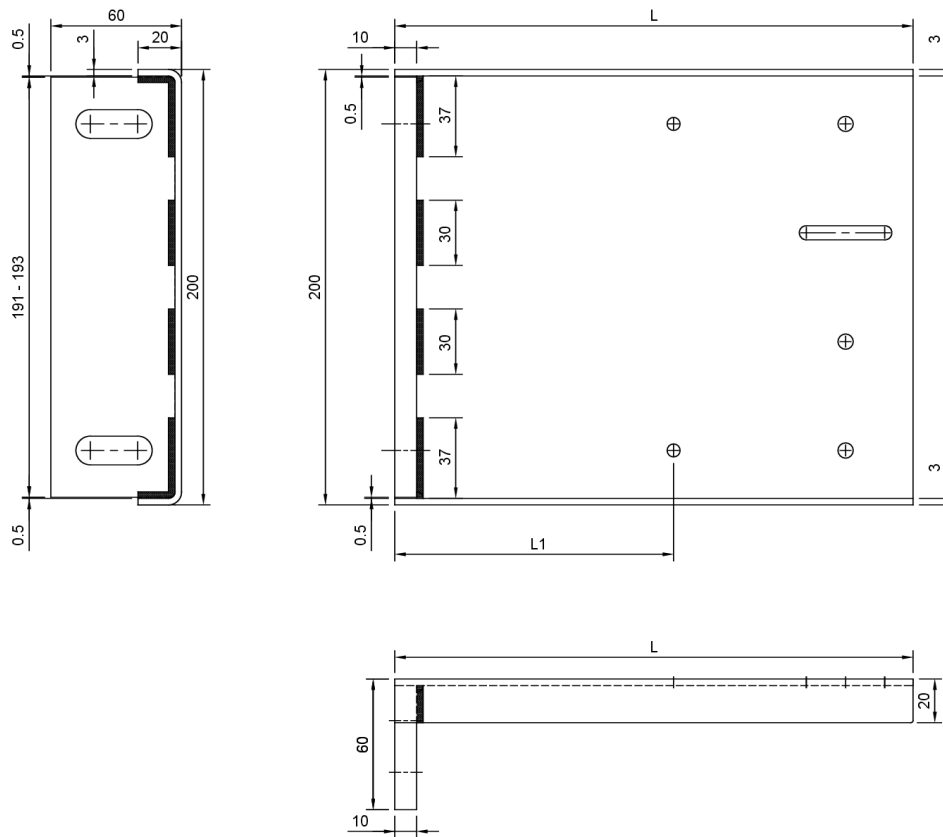
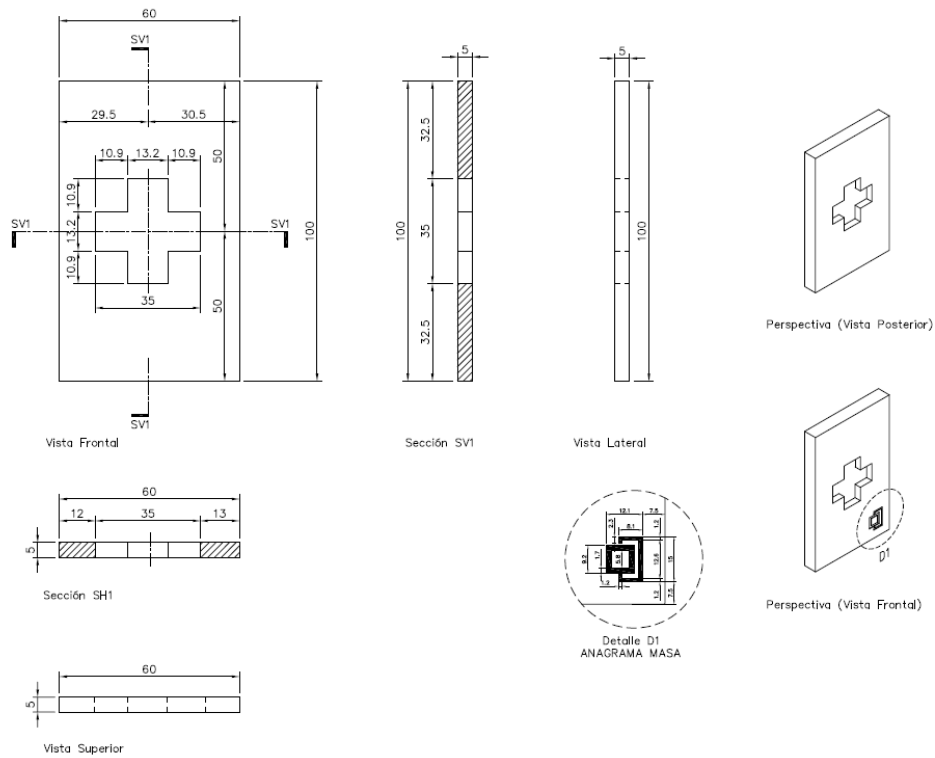

Figure A4.19: Brackets ES-INOX-(238/200; 267/200; 296/200 & 325/200)-E.



I



Figure A4.20a: Thermal bridge break piece. Termostop 100.

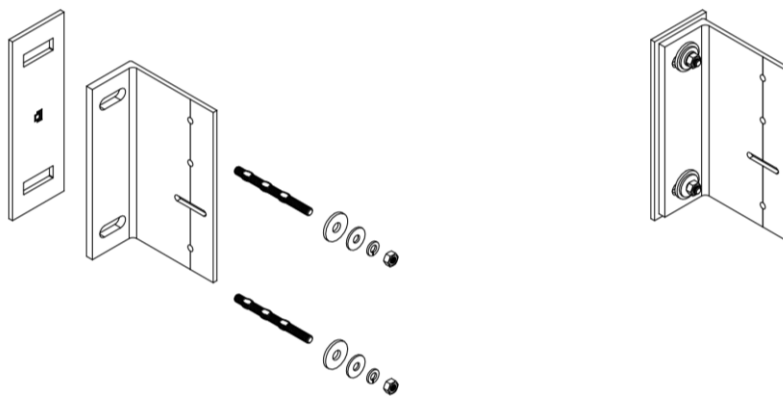
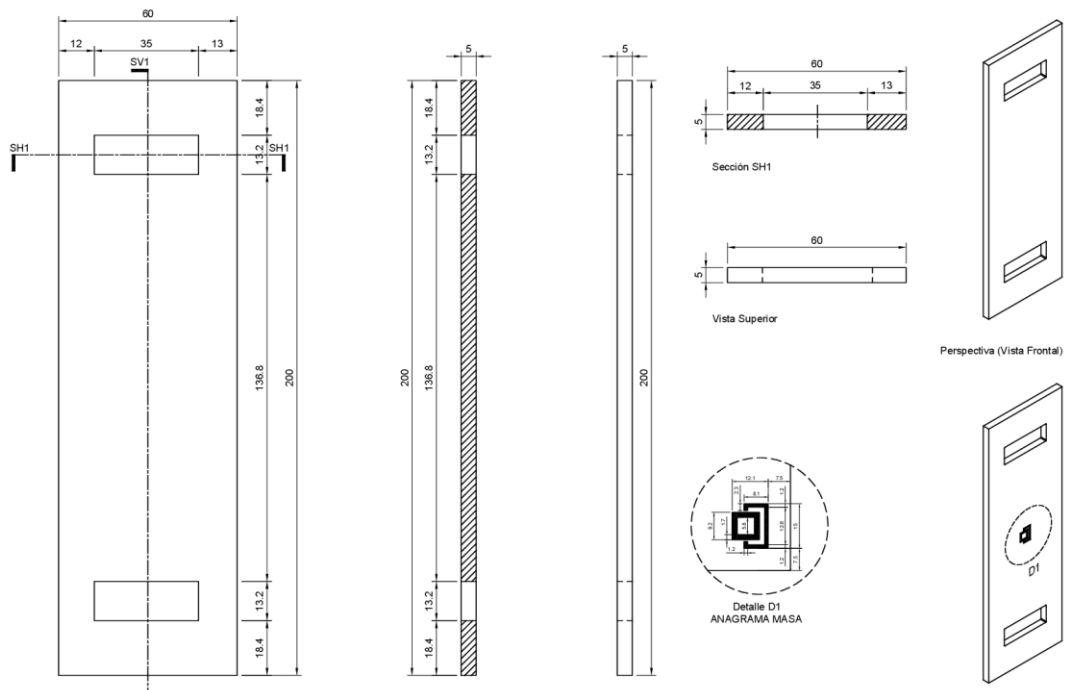



Figure A4.20b: Thermal bridge break piece. Termostop 200.

ANNEX 5: Subframe fixings and other components

A5.1. Subframe screws

Geometry characteristics			
Form	ST6,3x25 PB		
			
Dimensions (mm)	Drilling screw to fix horizontal profile to the vertical profile	ST6,3x25 PB	See figure A3.3.1

Material properties	Values		Reference
Type of material	Stainless steel Quality A2-70	Stainless steel Quality A4-80	EN ISO 3506-1
Elastic limit $R_{p0,2}$ (MPa)	450	600	EN ISO 3506-1
Tensile strength R_m (MPa)	700	800	EN ISO 3506-1
Elongation A (%)	0,4·d	0,3·d	EN ISO 3506-1
Thread characteristics	According to reference standard		EN ISO 3506-4
Form characteristics of the hexagon washer head screw	According to reference standard		EN ISO 15480
Drill hole characteristics	According to reference standard		EN ISO 10666

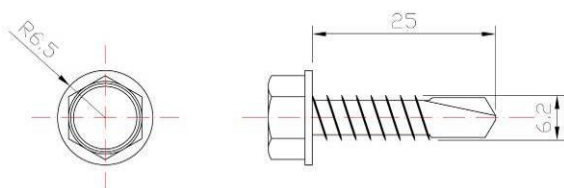

Figure A3.3.1: Screw ST6,3x25 PB.

A5.2. Other components

Other products that do not pertain to the kit but they are needed for the execution of the PF-ALU-PL kit in the works are the fixings between the brackets and the substrate. The main specifications to be met by these products to be used with the kit are:

- Fixings must be chosen according to the substrate or supporting structure material (concrete, masonry, timber or metal frame, etc.) and the resistance required due to wind load and dead load (pull-out and shear strength respectively).
- Minimum fixing diameter 8 mm. Minimum washer diameter 16 mm.
- Required minimum pull-out strength on substrate material: 4,0 kN.
- Required minimum shear strength: 4,0 kN.
- Fixings between the brackets and the substrate may be CE marked according to an ETA on the basis of the relevant EAD (see www.eota.eu) as long as this CE marking is mandatory in the Member State where the kit is used.

ANNEX 6: Design, installation, maintenance and repair criteria

A6.1 Design

The design of the subframe and fixings for fastener external skin elements using PF-ALU-PL kit should consider:

- For fastening cladding elements (the subframe is fixed on structural floors and also on a subframe wall), all the kit components defined in Annexes 2 to 5 may be used. However, for the fastening of wall elements, if the subframe is fixed only between structural floors, the vertical profiles and bracket types less than 80 should be avoided (e.g. profiles PF-AL-U-40, PF-AL-U-60 & PF-AL-T-60 and brackets ES-ALU-45 & ES-ALU-67).
- The vertical profiles must not be used with the brackets of lower dimensions (e.g. profile PF-AL-U-80 can be used with brackets ES-ALU-87 to ES-ALU-325 and ES-INOX-238 to ES-INOX-325 but cannot be used with bracket ES-ALU-67).
- The PF-ALU-PL kit can be used for skin elements with groove and thickness between 20 to 50 mm. The maximum weight and area shall be determined according to the mechanical properties of the kit components declared in this ETA (see sections 3.4 to 3.11). The maximum density that can be considered is 3000 kg/m³. The groove ($t = 5$ mm) shall be situated in the middle axis of the skin element thickness.
- For the GR-PL-46 fixing devices should be positioned between $A/4$ and $A/5$ of the skin element edge, where A is the length of the skin element.
- It is assumed that the substrate wall meets the necessary requirements regarding the mechanical strength (resistance to static and dynamic loads) and airtightness, as well as the relevant resistance regarding watertightness and water vapour.
- It is assumed that the skin element meets the necessary requirements regarding the mechanical resistance and hygrothermal behaviour.
- The verification of the designed system by means of calculation, taking into account the mechanical characteristic values of the kit components in order to resist the actions (dead loads, wind loads, etc.) applying on the specific works. National safety factors and other national provisions must be followed.
- The selection and verification of the anchors between the brackets and the external walls (substrate), taking into account the substrate material and the minimum resistance required (pull-out and shear resistance) according to the envisaged actions obtained from the mechanical calculation of the designed system.
- The accommodation of the designed system movements to the substrate or structural movements.
- The execution of singular parts of the façade.
- The corrosion protection of the designed system metallic components taking into account the category of corrosivity of the atmosphere of works (e.g. acc. ISO 9223).
- The drainability of the ventilated air space between the skin elements and the insulation layer or the external wall accordingly.
- An insulation layer is usually fixed on the external wall and should be defined in accordance with a harmonized standard or a European technical assessment.
- When the skin element joints are not watertight, the first layer behind ventilated air space (e.g. insulation layer) should be composed by materials with low water absorption.

A6.2 Installation

Installation of the subframe and fixings for fastener external skin elements using PF-ALU-PL kit should be carried out:

- According to the specifications of the manufacturer and using the components specified in this ETA.
- In accordance with the design and drawings prepared for the specific works. The manufacturer should ensure that the information on these provisions is given to those concerned.

- By appropriately qualified staff and under the supervision of the technical responsible of the specific works.

A6.3 Maintenance and repair

Maintenance of the subframe and fixings for fastener external skin elements using PF-ALU-PL kit includes inspections on site, taking into account the following aspects:

- the appearance of any permanent irreversible deformation.
- the presence of corrosion or presence of water accumulation.

When necessary, any repair to localized damaged areas must be carried out with the same components and following the repair instructions given by the manufacturer.