



## European Technical Assessment

**ETA 22/0188**  
of 19.04.2023



### General part

#### Technical Assessment Body issuing the ETA: ITeC

ITeC has been designated according to Article 29 of Regulation (EU) No 305/2011 and is member of EOTA (European Organisation for Technical Assessment).

**Trade name of the construction product**

**DESENFIRE**

**Product family to which the construction product belongs**

Fire protective boards.

**Manufacturer**

**MF INDUSTRIES**  
2 Avenue Élie Baylac,  
95660 Champagne-sur-Oise  
France

**Manufacturing plant(s)**

According to Annex N kept by ITeC.

**This European Technical Assessment contains**

14 pages including 1 annex which forms an integral part of this assessment

and

Annex N, which contains confidential information and is not included in the European Technical Assessment when that assessment is publicly available.

**This European Technical Assessment is issued in accordance with Regulation (EU) 305/2011, on the basis of**

European Assessment Document EAD 350142-00-1106.

**This version replaces**

ETA 22/0188 issued on 02.05.2022.

**General comments**

Translations of this European Technical Assessment in other languages shall fully correspond to the original issued document.

Communication of this European Technical Assessment, including transmission by electronic means, shall be in full (excepted the confidential Annex(es)).

## Specific parts of the European Technical Assessment

### 1 Technical description of the product

DESENFIRE is a fire protective board made of gypsum, fibres and vermiculite. The range of DESENFIRE boards assessed in this ETA is shown in the next table.

**Table 1:** DESENFIRE boards.

Board type	Thickness (mm)	Length (mm)	Width (mm)	Density (kg/m <sup>3</sup> )
DESENFIRE HD 25				
DESENFIRE THD 25	25 (-1/+3)			
DESENFIRE STR 25				
DESENFIRE HD 35	35 (-1/+3)	1000 ± 5	(50 – 1000) ± 5	1000 ± 10 %
DESENFIRE 45				
DESENFIRE HD 45	45 (-1/+3)			

The assembled systems require additional products for their installation, as described in the annexes of this ETA. These products cannot be CE marked on its basis, nor the installed system as a whole.

### 2 Specification of the intended use(s) in accordance with the applicable EAD

DESENFIRE is intended for the fire protection of ventilation ducts, multi-compartment smoke extraction ducts, and service ducts and shafts, i.e., category according to section 1.2.2 of EAD 350142-00-1106:

- Type 9: Fire protective products that contribute to the fire resistance of technical services assemblies in buildings.

The environmental use conditions assessed correspond to the following use category according to section 1.2.3 of EAD 350142-00-1106:

- Type Z<sub>2</sub>: Internal conditions excluding temperatures below 0°C, with humidity below 85% RH.

The provisions made in this ETA are based on a working life of the products of at least 25 years, provided that the conditions laid down in the manufacturer's instructions for the installation, use and maintenance are met. These provisions are based upon the current state of the art and the available knowledge and experience.

The indications given as to the working life cannot be interpreted as a guarantee given by the manufacturer or Assessment Body but are to be regarded only as a means for choosing the appropriate product(s) in relation to the expected economically reasonable working life of the works.

### 3 Performance of the product and reference to the methods used for its assessment

#### 3.1 Performance of the product

The assessment of DESENFIRE has been performed in accordance with EAD 350142-00-1106 *Fire protective board, slab and mat products and kits (September 2017)*.

**Table 2:** Performance of the product.

Product: DESENFIRE		Intended use: Fire protective product		
Basic requirement	Essential characteristic	Performance		
BWR 2 Safety in case of fire	Reaction to fire	A1		
	Resistance to fire <ul style="list-style-type: none"> <li>• Ventilation and smoke extraction ducts</li> <li>• Service ducts and shafts</li> </ul>	See Annex A		
			Table A1	
			Table A2	
	Durability	Type Z <sub>2</sub>		
BWR 6 Energy economy and heat retention	Water vapour transmission	G [kg/s]	1,46 x 10 <sup>-8</sup>	
		g [kg/(s·m <sup>2</sup> )]	7,41 x 10 <sup>-7</sup>	
		W [kg/(s·m <sup>2</sup> ·Pa)]	5,09 x 10 <sup>-10</sup>	
		Z [(s·m <sup>2</sup> ·Pa)/kg]	1,97 x 10 <sup>9</sup>	
		δ [kg/(s·m·Pa)]	2,25 x 10 <sup>-11</sup>	
		μ [-]	8,63	
	Sd [m]	0,38		

The rest of characteristics included in EAD 350142-00-1106 have not been assessed in this ETA.

## 3.2 Methods used for the assessment

### 3.2.1 Reaction to fire

The performance of the DESENFIRE boards has been tested according to EN ISO 1182<sup>1</sup> and EN ISO 1716<sup>2</sup>. Classification is given in accordance with EN 13501-1<sup>3</sup> and Regulation (EU) 2016/364.

### 3.2.2 Resistance to fire

The fire resistance performance of the ventilation ducts has been determined in accordance with EN 1366-1<sup>4</sup>.

The fire resistance performance of the service ducts and shafts has been determined in accordance with EN 1366-5<sup>5</sup>.

The fire resistance performance of the multi-compartment smoke extraction ducts has been determined in accordance with EN 1366-8<sup>6</sup>.

### 3.2.3 Durability

The durability of the DESENFIRE boards has been assessed for Type Z<sub>2</sub> conditions in accordance with section 2.2.2.3 of EAD 350142-00-1106.

### 3.2.4 Water vapour transmission

The water vapour transmission (water vapour resistance factor,  $\mu$ ) of the DESENFIRE boards has been determined in accordance with EN ISO 12572<sup>7</sup>.

---

<sup>1</sup> EN ISO 1182 Reaction to fire tests for products. Non-combustibility test.

<sup>2</sup> EN ISO 1716 Reaction to fire tests for products. Determination of the gross heat of combustion (calorific value).

<sup>3</sup> EN 13501-1 Fire classification of construction products and building elements. Part 1: Classification using data from reaction to fire tests.

<sup>4</sup> EN 1366-1 Fire resistance tests for service installations. Part 1: Ventilation ducts.

<sup>5</sup> EN 1366-5 Fire resistance tests for service installations. Part 5: Service ducts and shafts.

<sup>6</sup> EN 1366-8 Fire resistance tests for service installations. Part 8: Smoke extraction ducts.

<sup>7</sup> EN ISO 12572 Hygrothermal performance of building materials and products. Determination of water vapour transmission properties.

#### 4 Assessment and verification of constancy of performance (AVCP) system applied, with reference to its legal base

According to the Decision 1999/454/EC of the European Commission, the system of AVCP (see EC delegated Regulation (EU) No 568/2014 amending Annex V to Regulation (EU) 305/2011) given in the following table applies.

**Table 3:** AVCP System.

Product(s)	Intended use(s)	Level(s) or class(es)	System(s)
Fire protective products	For fire compartmentation and/or fire protection or fire performance	Any	1

#### 5 Technical details necessary for the implementation of the AVCP system, as foreseen in the applicable EAD

All the necessary technical details for the implementation of the AVCP system are laid down in the Control Plan deposited with the ITeC and agreed in accordance with EAD 350142-00-1106, section 3.

The Control Plan is a confidential part of the ETA and only handed over to the notified product certification body involved in the assessment and verification of constancy of performance.

The factory production control operated by the manufacturer shall be in accordance with the above-mentioned Control Plan.

Issued in Barcelona on 19 April 2023

by the Catalonia Institute of Construction Technology.



Ferran Bermejo Nualart  
Technical Director, ITeC

## ANNEX A. Specification and assessment of fire resistant ventilation ducts, multi-compartment smoke extraction ducts and service ducts and shafts made of DESENFIRE boards

### A.1 Resistance to fire performance

The ducts made of DESENFIRE boards have the resistance to fire performance as shown in the next tables, provided that the installation provisions described in the manufacturer's instructions and in this Annex are met.

**Table A1:** Resistance to fire performance of the ventilation ducts and multi-compartment smoke extraction ducts.

Board type	Ventilation duct		Multi-compartment smoke extraction duct	
	Maximum duct section (mm x mm)	Performance	Maximum duct section (mm x mm)	Performance
DESENFIRE HD 25	1250 x 1000	EI 60 S (ve-ho i ↔ o)	1250 x 1000	EI 60 (ve-ho) S 1500 multi
DESENFIRE THD 25	1250 x 1000	EI 90 S (ve-ho i ↔ o)	1250 x 1000	EI 90 (ve-ho) S 1500 multi
DESENFIRE STR 25	1250 x 1000	EI 120 S (ve-ho i ↔ o)	1250 x 1000	EI 120 (ve-ho) S 1500 multi
DESENFIRE HD 35	1250 x 1000	EI 120 S (ve-ho i ↔ o)	1250 x 1000	EI 120 (ve-ho) S 1500 multi
DESENFIRE 45	2000 x 1600	EI 120 S (ve-ho i ↔ o)	1250 x 1000	EI 120 (ve-ho) S 1500 multi
			2000 x 1600	EI 120 (ve-ho) S 500 multi
DESENFIRE HD 45	1250 x 1000	EI 180 S (ve-ho i ↔ o)	1250 x 1000	EI 120 (ve-ho) S 1500 multi
	2000 x 1600	EI 120 S (ve-ho i ↔ o)	2000 x 1600	EI 120 (ve-ho) S 500 multi

**Table A2:** Resistance to fire performance of the service ducts and shafts.

Board type	Service shaft		Service horizontal duct	
	Maximum duct section (mm x mm)	Performance	Maximum duct section (mm x mm)	Performance
DESENFIRE 45 DESENFIRE HD 45	200 x 200	EI 120 (i ↔ o) ve	1000 x 500	EI 180 (i ↔ o) ho
				EI 240 (i → o) ho
	50 x 50	EI 180 (i ↔ o) ve	50 x 50	EI 240 (i → o) ho

The provisions given in this ETA regarding the ducts' installation, which are based on the tests and assessment carried out, should be followed to achieve the given performance. However, the range of installed systems will vary depending on the design of the ventilation, smoke extraction or service ductwork and, therefore, the system installation shall always be carried out in accordance with the manufacturer's instructions, which shall be consistent with the assessment carried out to achieve the performance given in table A1 and table A2.

## A.2 Ventilation and smoke extraction ducts

### A.2.1 General

The rectangular horizontal and vertical ducts are composed by single layer DESENFIRE boards with a thickness from 25 to 45 mm in function of the required resistance to fire, as given in table A1.

The ducts are made of segments of 1000 mm length. The maximum dimensions of internal duct section are 1250 mm x 1000 mm (width x height), except for those cases where higher internal sections up to 2000 mm x 1600 mm (width x height) have been assessed, as shown in table A1 (see section A.2.5 for specific installation provisions of big section ducts). DESENFIRE boards have a rebate at two of the edges for assembly of the duct section at the corners (see figure A1). A longitudinal joint along the duct direction is allowed at the long side of the duct, also executed with a joint rebate between boards (see figure A1). All duct joints are formed by a rebated edges of the boards except joints between duct segments that are butt joints. All joints are sealed inside with a gypsum-based adhesive before the boards are fitted together. Additionally, all joints are coated inside and/or outside the duct with a sealing strip made from vegetable fibres and a gypsum-based paste according to EN 13279, forming a tight cord with a minimum width between 50 mm and 100 mm depending on the duct size.

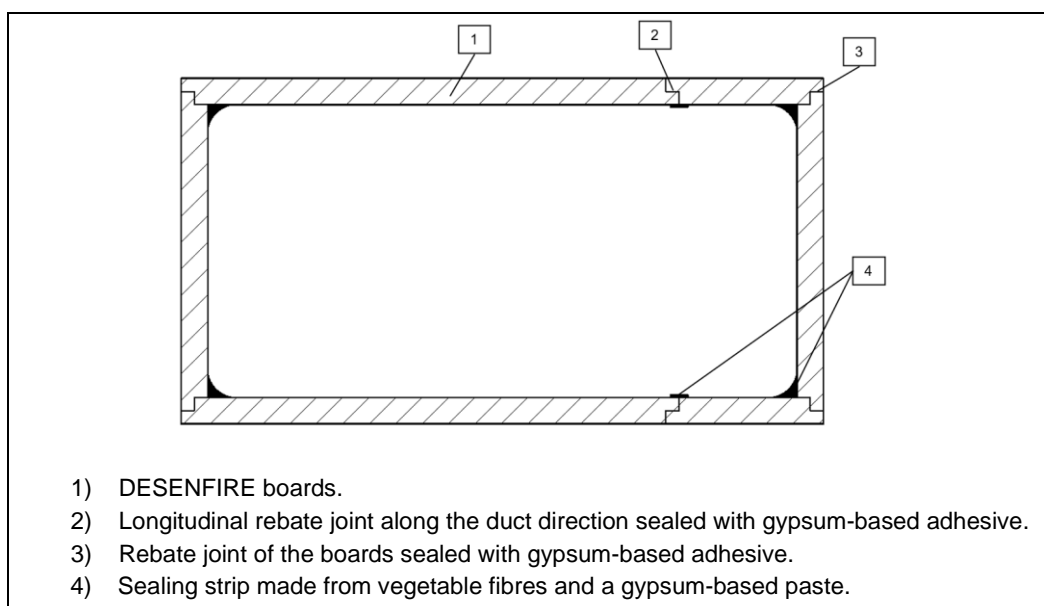

**Figure A1:** Duct cross-section.



**Figure A2:** Duct general view.



Duct side branches, T-pieces or direction changing pieces can be installed according to the manufacturer’s instructions, based on the same constructive criteria as for the main duct.

Ventilation ducts have been assessed to work at a pressure difference between – 500 Pa to + 500 Pa and smoke extraction ducts in accordance with the performance given in table A1.

### A.2.2 Stiffeners for horizontal ducts

In the case of horizontal ducts, a tube of external diameter of 90 mm and a hole of 10 mm x 10 mm, made from the same material as DESENFIRE boards, is positioned every 1000 mm at the joints between duct segments and, when relevant, at the longitudinal joint allowed at the long side of the duct. The stiffener tube is composed by two semicircle pieces glued together with a gypsum-based adhesive. The joints between the stiffeners and the duct internal faces are sealed with a strip made from vegetable fibres and a gypsum-based paste according to EN 13279, forming a cord of approximately 2 mm thickness.

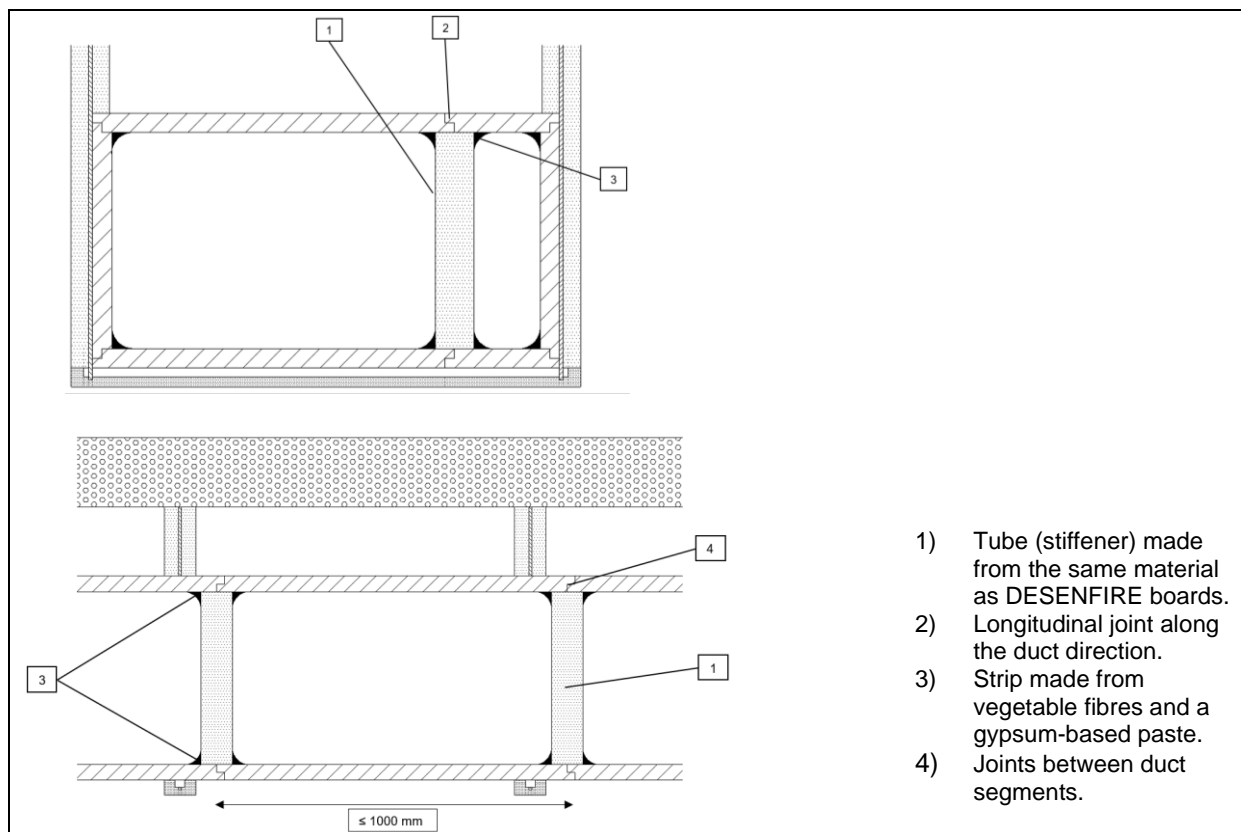

Figure A3: Stiffener viewed in a duct cross-section (image above) and in a duct longitudinal section (image below).



Figure A4: Detail of duct stiffener (semicircle piece).

### A.2.3 Suspension elements for horizontal ducts

The suspension system is installed every 1000 mm maximum and consist of two hangers (galvanised steel M8 threaded rods) fixed to a U-profile (galvanised steel 25/25/25 mm and 2 mm thickness) beneath the duct.

The hangers are protected with a tube of external diameter of 90 mm and a hole of 10 mm x 10 mm, made from the same material as DESENFIRE boards. The protective tube is composed by two semicircle pieces glued together around the hanger and also to the duct face with a gypsum-based adhesive.

The suspension U-profile is protected by a U-shaped shell of external dimensions 100 mm x 60 mm and 35 mm thickness, made from the same material as DESENFIRE boards, and glued to the lower surface of the duct and to the hangers' protective tube with a gypsum-based adhesive.

When a duct side branch is installed, the first suspension element shall be placed at a distance of 100 mm from the main duct.

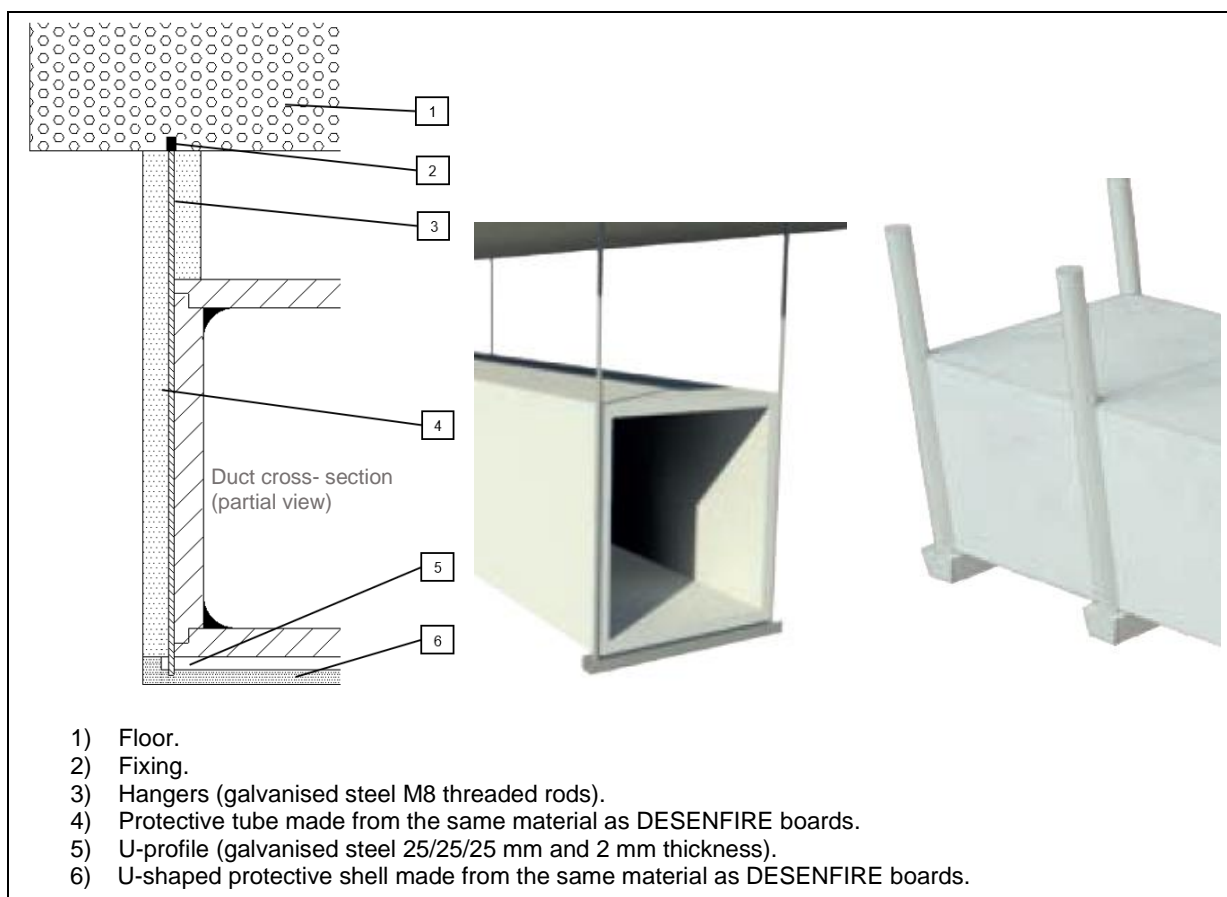

**Figure A5:** General view of suspension elements.

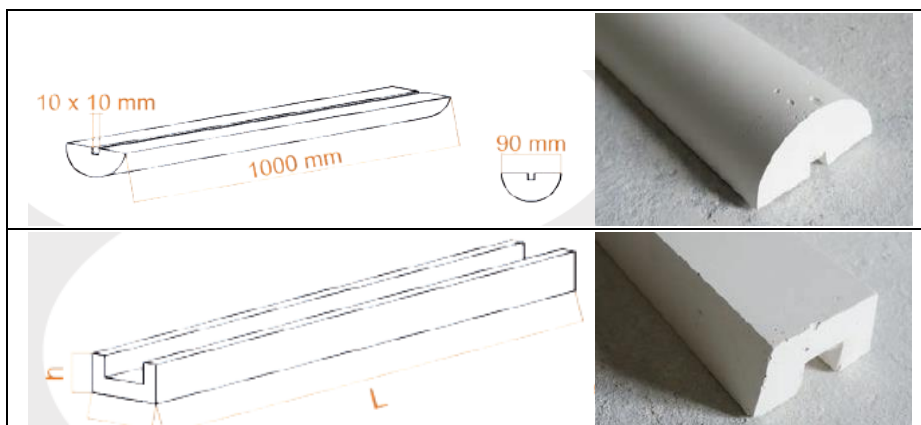

Figure A6: Detail of suspension elements' protection.

#### A.2.4 Supporting construction

The ducts can pass rigid walls with a minimum thickness of 150 mm, minimum density of 550 kg/m<sup>3</sup> and minimum resistance to fire as the passing duct.

The ducts can pass rigid floors with a minimum thickness of 150 mm, minimum density of 2200 kg/m<sup>3</sup> and minimum resistance to fire as the passing duct.

The gap between the passing duct and the edge of the supporting construction opening is 50 mm maximum. The gap is fitted with strips of rock wool slab of minimum density 120 kg/m<sup>3</sup> and sealed at both sides with a strip made from vegetable fibres and a gypsum-based paste according to EN 13279, with a minimum thickness of 50 mm.

For vertical ducts passing through the floor, a strip of 100 mm height and a minimum thickness to completely cover the gap, made by adding layers of the same DESENFIRE boards as used to build the duct, is placed at the upper side of the floor, glued to the duct external face with a gypsum-based adhesive and sealed with a strip made from vegetable fibres and a gypsum-based paste according to EN 13279 (see figure A7). This strip is placed at least at two sides of the duct.

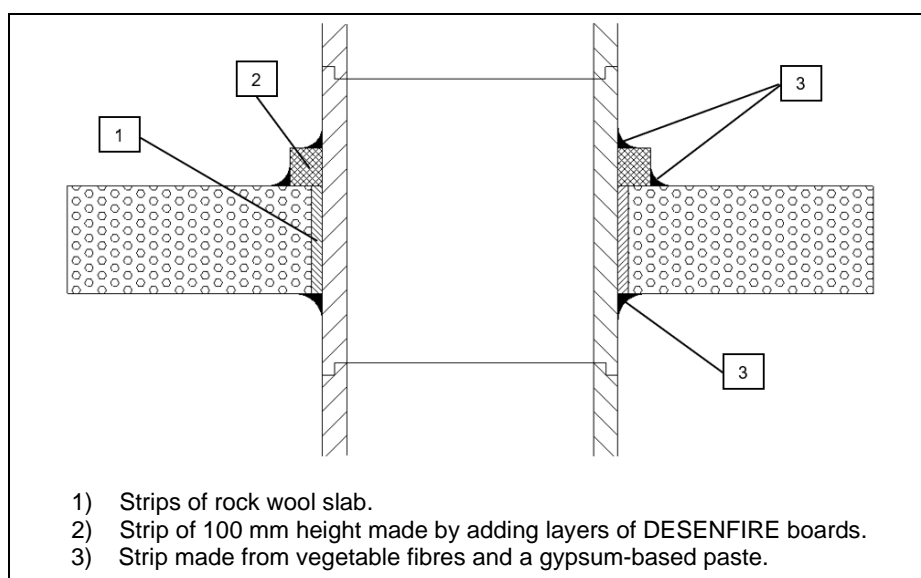
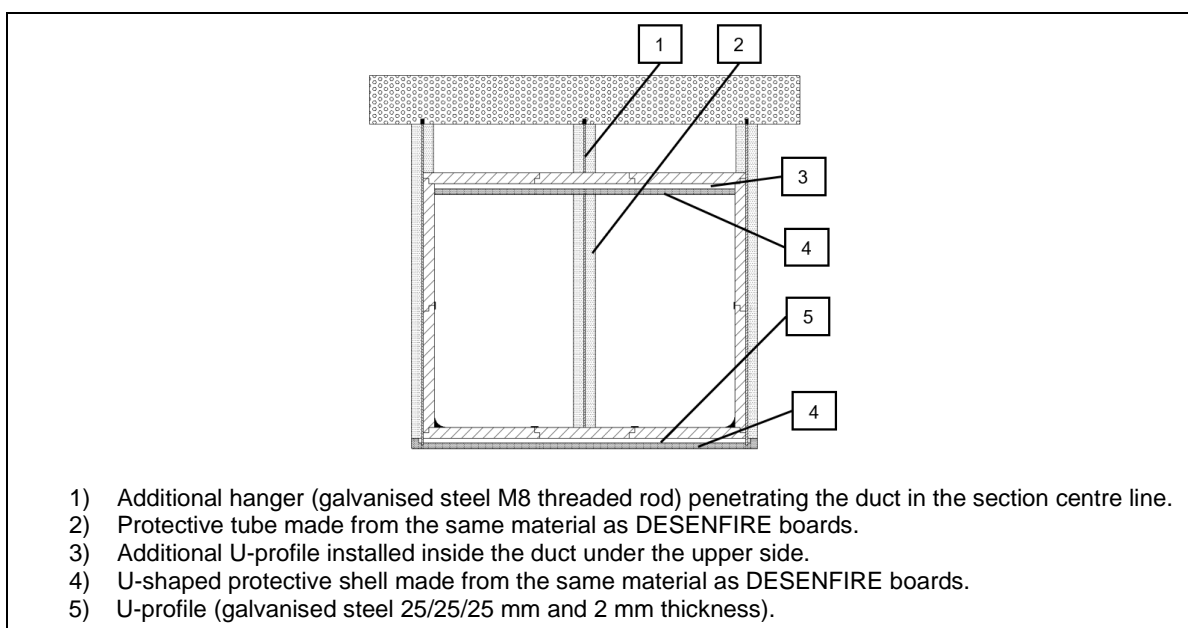

Figure A7: Duct passing through the floor (section).

### A.2.5 Specific provisions for big section ducts

For ducts with internal sections between 1250 mm x 1000 mm and 2000 mm x 1600 mm, as shown in table A1, the duct section must be reinforced as follows.

The suspension system is installed as described in section A.2.3 for standard ducts, but adding an additional hanger (galvanised steel M8 threaded rod) penetrating the duct in the section centre line, fixed to a supporting U-profile beneath the duct. Additionally, a U-profile (galvanised steel 25/25/25 mm and 2 mm thickness) is also installed inside the duct under the upper side. The hangers and profiles are protected as specified in section A.2.3.



**Figure A8:** Reinforcement of big section ducts with 3 hangers (duct cross-section).

Alternatively, the big section horizontal ducts can also be suspended with two protected hangers following the specification in section A.2.3, but using supporting UPN 80 steel profiles beneath the duct and inside the duct under the upper side. UPN 80 profiles are protected by a U-shaped shell of external dimensions 170 mm x 90 mm and internal dimensions of 90 mm x 60 mm, made from the same material as DESENFIRE boards, and glued to the duct surface and to the hangers' protective tube with a gypsum-based adhesive.

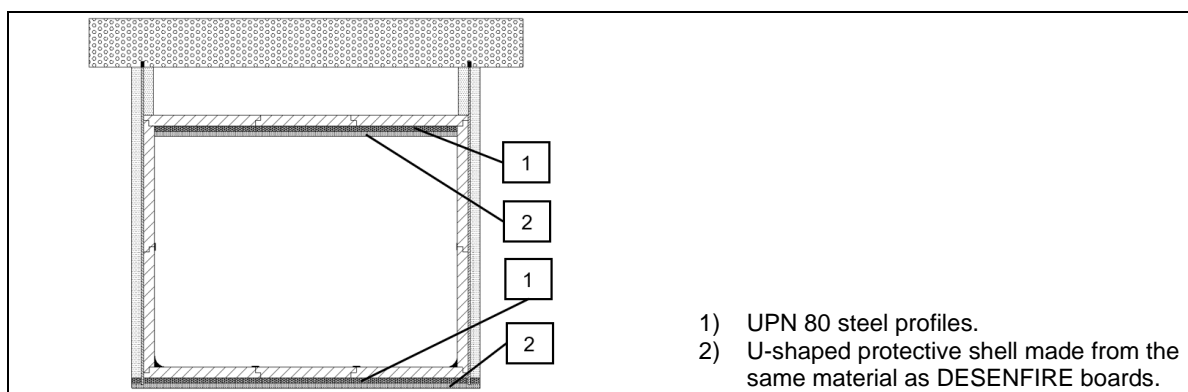

**Figure A9:** Reinforcement of big section ducts with UPN profiles (duct cross-section).

## A.3 Service ducts and shafts

### A.3.1 General

The rectangular horizontal service ducts and vertical shafts are composed by a single layer of DESENFIRE boards of thickness 45 mm to meet the resistance to fire performance as given in table A2.

The ducts and shafts are made of segments of 1000 mm length. The maximum dimensions of internal duct section are 1000 mm x 500 mm (width x height) in the case of horizontal service ducts and 200 mm x 200 mm in the case of vertical service shafts.

DESENFIRE boards have a rebate at two of the edges for assembly of the duct section at the corners (see figure A1). A longitudinal joint along the duct direction is allowed at the long side of the duct, also executed with a joint rebate between boards (see figure A1). All duct joints are formed by a rebated edges of the boards except joints between duct segments that are butt joints. All joints are sealed inside with a gypsum-based adhesive before the boards are fitted together. Additionally, all joints are coated inside and/or outside the duct with a sealing strip made from vegetable fibres and a gypsum-based paste according to EN 13279, forming a tight cord with a minimum width between 50 mm and 100 mm depending on the duct size.

### A.3.2 Horizontal service ducts

#### A.3.2.1 Stiffeners

In the case of horizontal service ducts, internal duct stiffeners shall be installed in accordance with section A.2.2 of this ETA. Duct stiffeners are not required for horizontal service ducts of internal section up to 50 mm x 50 mm.

#### A.3.2.2 Suspension elements

In the case of horizontal service ducts, the duct suspension system shall be installed in accordance with section A.2.3 of this ETA.

#### A.3.2.3 Service load

Horizontal service ducts have been assessed with fire exposure from inside ( $i \rightarrow o$ )<sup>8</sup> for a service load of 50 kg/m<sup>2</sup> (duct section of 1000 mm x 500 mm) and 26 kg/m<sup>2</sup> (duct section of 50 mm x 50 mm).

#### A.3.2.4 Access panel

An access panel of maximum dimensions 800 mm x 800 mm can be installed in horizontal service ducts with fire exposure from inside ( $i \rightarrow o$ )<sup>8</sup>. The access panel is made up of a steel frame, covered with a strip made from vegetable fibres and a gypsum-based paste according to EN 13279, in which a fire protective board DESENFIRE is placed. The access panel joints are sealed with an intumescent strip.

Design and installation of the access panel technical solution shall be carried out in accordance with the manufacturer's instructions.

---

<sup>8</sup> See table A2.

### A.3.3 Supporting construction

The ducts can pass rigid walls with a minimum thickness of 150 mm, minimum density of 550 kg/m<sup>3</sup> and minimum resistance to fire as the passing duct.

The ducts can pass rigid floors with a minimum thickness of 150 mm, minimum density of 550 kg/m<sup>3</sup> and minimum resistance to fire as the passing duct.

In the case of horizontal service ducts, the gap between the passing duct and the edge of the supporting construction opening is 25 mm maximum. The gap is fitted with ceramic wool of minimum density 96 kg/m<sup>3</sup> and sealed at both sides with a strip made from vegetable fibres and a gypsum-based paste according to EN 13279, with a minimum thickness of 50 mm.

In the case of service shafts, the duct does not penetrate through the floor but abuts it, levelled at the opening edge (non-continuous shaft, see figure A10). At the upper side, the shaft starts and is supported on the floor. The abutting edges of the DESENFIRE boards of the shaft section in contact with the floor are glued with a gypsum-based adhesive and sealed, both internally and externally, with a strip made from vegetable fibres and a gypsum-based paste according to EN 13279

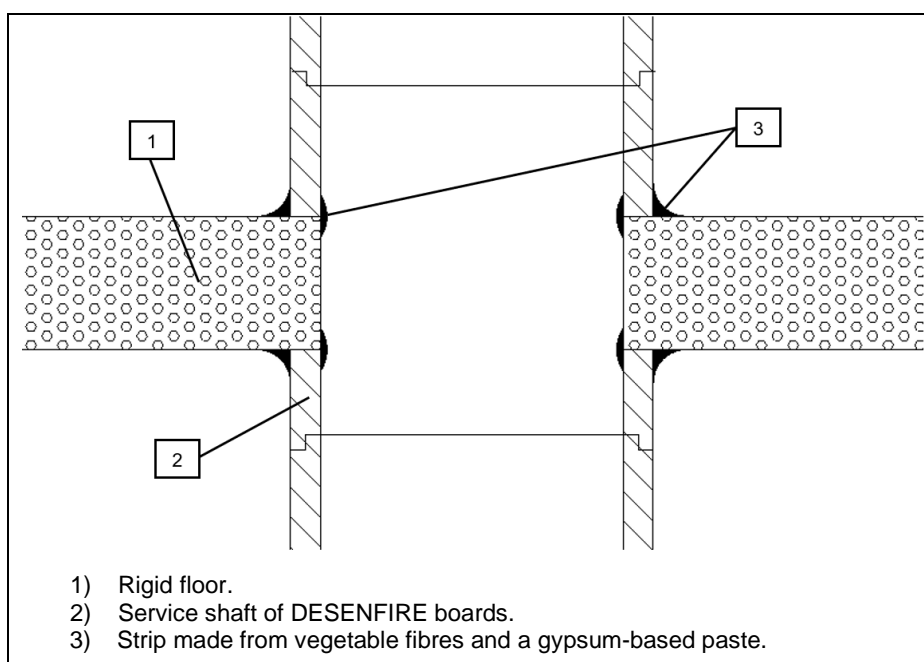

**Figure A10:** Service shaft passing through the floor (section).